

LITHUANIAN INSTITUTE OF AGRARIAN ECONOMICS

**AGRICULTURAL AND FOOD SECTOR
IN LITHUANIA**

2008

VILNIUS, 2009

General Editor Dr. Rasa Melnikienė
Scientific Editor Prof. Habil. Dr. Antanas Poviliūnas
Reviewer Assoc. Prof. Dr. Sigitas Vaitkevičius

An analytical review of the Lithuanian agricultural and food sector in 2008 is aimed at providing information to representatives of governmental and self-governing authorities, scientific research and study institutions, and all interested in the development of agricultural and food sector, pisciculture and rural areas.

ABBREVIATIONS

AB – Joint Stock Company
AWU – Annual Work Unit
CAP – EU Common Agricultural Policy
CIS – Commonwealth of Independent States
CN – combined nomenclature
EU – European Union
EU-12 – Member States since 2004 and 2007
EU-15 – the old Member States
EU-27 – all EU Member States in 2007
FADN – Farm Accountancy Data Network
GovRL – the Government of the Republic of Lithuania
LAG – Local action group
LIAE – Lithuanian Institute of Agrarian Economics
LTL – Lithuanian Litas
MoA – Ministry of Agriculture of the Republic of Lithuania
RDP – Rural Development Programme
SME – small/medium size enterprise
SPD – Single Programming Document
UAA- Utilised Agricultural Area
USA – The United States of America

TABLE OF CONTENTS

FOREWORD	4
I. LITHUANIAN AGRARIAN SECTOR IN THE EU CAP CONTEXT	5
1. Agricultural and food sector in the national economy. Rasa Melnikienė ..	5
2. EU and national support and its impact on the development of agricultural and food sector in Lithuania Agnė Čiapaitė, Vilma Dapkutė ..	11
II. LITHUANIAN AGRICULTURAL AND FOOD SECTOR IN THE SINGLE MARKET	20
1. Changes in the trade of agricultural and food products on the domestic market. Albertas Gapšys	20
2. Tendencies for foreign trade in agricultural and food products. Tamara Petuchova, Audronė Laskauskienė	22
3. Competitiveness of agricultural and food products on the domestic and foreign markets.....	34
3.1. Cereals. Vidmantas Bradūnas	34
3.2. Milk. Deiva Mikelionytė	51
3.3. Meat. Albertas Gapšys	62
III. STRUCTURAL CHANGES IN THE AGRICULTURAL AND FOOD SECTOR	78
1. Gross agricultural production. Irena Kriščiukaitienė, Selemutė Andrikienė	78
2. Structure of agro-food industry entities. Nijolė Pelanienė, Aldona Stalgienė, Aistė Galnaitytė	80
SUMMARY	93

FOREWORD

This is the tenth edition of the annual analytical survey prepared by the Lithuanian Institute of Agrarian Economics (LIAE) on agriculture, processing industry, fisheries and rural development. This survey was prepared referring to the statistical information, accountability data of companies within this sector of the national economy, and the findings of surveys carried out by the LIAE staff.

Readers of the publication will have a nice opportunity to analyze the achievements and problems of the Lithuanian agricultural and food sector during the five year period after joining the EU and the single market, ways and methods of the EU and the national agricultural policy in addressing the challenges.

Surveys prepared by the LIAE for the previous period of the Lithuanian agriculture and food sector covering the five year period before joining the EU, provides with a good opportunity for comparison of the two periods. Notice should be given to the publication of 2004 where data is provided for the five year period before joining the EU.

Given readers were interested in earlier periods of developments in Lithuanian agriculture and food industry, problems and solutions, information may be obtained from the LIAE editions of 1999 and 2000.

Data of the survey in all ten editions is provided following single methodology and structure aimed at retaining the possibility for comparing the essential tendencies.

This publication presents changes in the development of indicators of agriculture and food industry giving more attention to the events, documents and outcomes of the sector in 2008. The year of 2008 is significant because it was the eve of meeting hardships of the crisis, therefore analysis of activities by companies in the sector of agriculture and food industry gives the feeling of getting ready for the beginning of hard times.

As every year before some preliminary statistical indicators of 2008 were used in the survey. Final indicators and economic and financial outcomes will be reflected later in the publications of the Department of Statistics to the Government of the Republic of Lithuania and in the LIAE survey of the next year.

The publication is aimed at everybody interested in the achievements and problems of the agrarian and food sector. Information provided here might be useful as for agricultural specialists and scientists, farmers and entrepreneurs, as for teachers and students.

We are sincerely grateful to the Heads of the Lithuanian Department of Statistics and the Ministry of Agriculture of the Republic of Lithuania and their staff members for the provided statistical information and advice.

Dear readers, we are kindly looking forward to your remarks, comments and proposals.

Dr. Rasa Melnikienė,
Director of the Lithuanian Institute of Agrarian Economics

I. AGRARIAN SECTOR OF LITHUANIA IN THE EU CAP CONTEXT

1. Agricultural and food sector in the national economy

Lithuania has already celebrated the fifth anniversary of the EU membership. During this period agricultural and food sector of Lithuania took the advantage of the common market overcoming at the same time the challenges of the increasingly growing competition and the requirements of consumers. The EU support was among the key factors for meeting the challenges: the scope of production and export of agricultural and food products was increasing, the structure of farms was improving leading to the growth of labour efficiency and the income of farmers. Favourable tendencies were more rapidly developing in the sector of agriculture and food industry in comparison with other sectors of the economy. On the other side, Lithuanian farmers have also experienced the impact of global changes on the agricultural market and the climate change influenced by the global climate warming. The global economic crisis of 2008 has become a heavy economic burden for the sector, because of the tightened bank policy and the reduced scope of loans. However, even in the face of economic hardships, agriculture remains among the well established sectors in the Lithuanian economy.

Agricultural and food products. Analysis of structural changes in the national economy of Lithuania revealed that from the point of view of creating value added, employment, and expanding export, agriculture (including hunting and forestry) remained among the key sectors of the economy. Though the proportion of agriculture in the total value added of 2008 remained the same as in 2007 – 4.4%, and only slightly varied during the period of 2004–2008, the value added created during the period of 2004–2008 in agriculture (under current basic prices) by the expression of the value, increased by 1.7 times (increased by 13 percentage points in 2008) and accounted for LTL 4 393,4 million in 2008. Input of agriculture into the national economy of Lithuania is much more solid than in many other EU states, where industrial sectors and services dominate in the structure of the national economy. The value added in the old EU countries created by agriculture and the related sectors in 2008 accounted only for 1.6%, and in comparison to 2004, decreased by 0.4 per cent point. This indicator was slightly higher according to the EU-27 average and accounted for 1.8% in 2007. In comparison with the neighbouring EU countries, the share of value added created by Lithuanian farmers is similar to the value added created in Poland, and much higher than in other Baltic states.

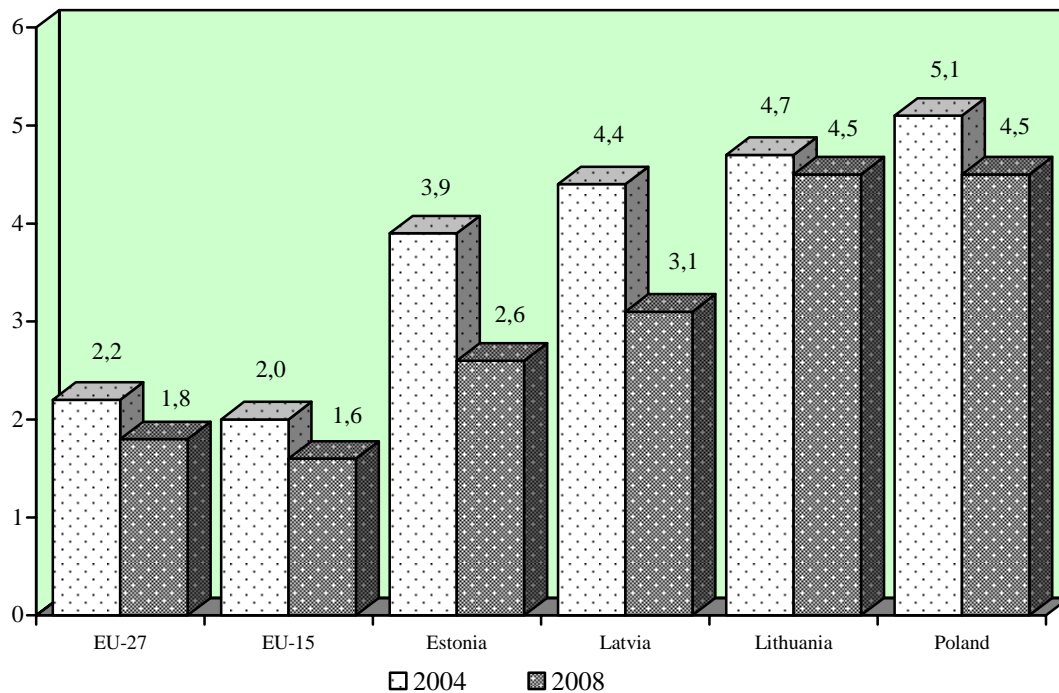

Fig. 1.1. The share of value added created in agriculture in the total value added in 2004 and 2008, in per cent

Source: Eurostat data.

Assessment of tendencies in the development of the sector within the period of five years membership in the EU, indicate clearly that value added created in agriculture was increasing more rapidly than the average in the national economy, where value added increased by 1.5 times within the reference period. However, it should be noted that the growth of value added created in the sector of agriculture was influenced more than in other sectors by the increased prices of agricultural production and the increased support to agriculture. The assessment of the growth of value added in agriculture, expressed in the chain-linked volume, indicate the change of 5 percentage points during the period of 2004–2008, whereas the annual price index of agricultural products in 2005 reached 104.7%, in 2006 – 106.5%, and in 2007 – 117.6%.

Though prices of some agricultural products (milk, grain, etc.) started dropping in 2008, the total annual price index remained positive – 110.0%.

The gross value added created in the sector of food, beverages and tobacco was also rapidly increasing, and amounted to LTL 3 493,3 million in 2008. In comparison with 2007 it increased by 8.3%, and in comparison with 2004 – even by 1.6 times. However, the share of food, beverage and tobacco sector in the national structure of gross value added was slowly decreasing and accounted for 3.5% in 2008 (in 2004 and 2005 – for 3.8%).

Table 1.1. Macroeconomic indicators of the agricultural and food sector in 2004–2008

Indicators	2004	2005	2006	2007	2008*
Gross domestic product, at current prices, mill. Litas	62697,8	72060,4	82792,8	98138,7	111498,7
Gross agricultural production, at current prices, mill. Litas	4552,3	5117,3	4913,0	6912,2	7092,1
Gross value added created in agriculture, hunting and forestry, mill. Litas	2595,6	3086,4	3154,9	3873,1	4393,4
Share of agriculture, hunting and forestry in gross value added, %	4,6	4,7	4,2	4,4	4,4
Gross value added created in manufacture of food products, beverages and tobacco products, mill. Litas	2 178,6	2 463,5	2 683,2	3 225,0	3 493,3
Share of manufacture of food products, beverages and tobacco products in gross value added, %	3,8	3,8	3,6	3,7	3,5
Exports of agricultural and food products, mill. Litas	2956,5	4208,8	5416,6	7345,6	8876,0
Share of agricultural and food products in total exports, %	11,5	12,8	13,9	17,0	16,0
Imports of agricultural and food products, mill. Litas	2954,6	3699,1	4952,8	6097,3	8105,2
Share of agricultural and food products in total imports, %	8,6	8,6	9,3	9,9	11,2
Foreign trade balance of agricultural and food products, mill. Litas	1,9	509,7	463,8	1248,3	770,8

* Preliminary data.

Sources: Data of the Department of Statistics at the GovRL, and Eurostat.

Export dynamics and structure. Lithuanian agricultural entities and food production companies took the advantage of the free movement of goods on the common market, which has opened for Lithuania after the accession to the EU, retaining at the same time the traditional Lithuanian markets outside the EU. Export is among the key criteria indicating the potential and competitiveness of the sector. Even before the membership in the EU Lithuanian agricultural and food sector covered a substantial part of Lithuanian export. According to the data of the Lithuanian Department of Statistics, value of export in agricultural and food products in 2004 accounted for 11.5% of the total national export. During the five year period of membership in the EU export in agricultural and food products increased by 3.0 times, and accounted for 16.0% of the total export value in 2008, amounting to LTL 8 876 million.

Import of agricultural and food products was also increasing. In 2008 import value amounted to LTL 8 105,2 million, and increased by 1.3 times in comparison to 2007, and by 2.7 times more than in 2004.

Foreign trade turnover of 2008 increased by 1.3 times in comparison to 2007 amounting to LTL 17 billion. Positive foreign trade balance in food products achieved in 2004 amounted to LTL 770,8 million in 2008.

In 2008 major partners in foreign trade of agricultural and food products were Russia, Latvia, Germany, Poland, Estonia, and the United Kingdom. Export to the EU-27 amounted to LTL 5 088,9 million in 2008, and the largest share of agricultural and food products, as in 2007, was exported into the EU-15 (30% of the total national export of Lithuania). At the same time Lithuanian producers managed to keep their positions on the traditional Eastern markets, where Lithuanian trade marks are well known. In 2008, as compared with 2007, export into third countries increased by 1.6 times and accounted for 42.7% of the total national export. The largest comparative weight in the structure of export in agricultural and food products fell for milk and milk products (14.3%), however, export decreased by 4.4% in comparison to 2007, because of the drop in prices on milk products. Export in grain has significantly increased – by 2.1 times, amounting to LTL 1 117,2 million. In total Lithuania exported 1 604 thousand tons of various grain crops: 1 127 thousand tons of wheat, 316 thousand tons of barley, 60 thousand tons of rye, 48 thousand tons of buckwheat, 38 thousand tons of corn, 13 thousand tons of oats, and over 2 thousand of other grain crops.

Though after joining the EU Lithuania remains a well-established country of growing export in agricultural and food products with a positive foreign trade balance, certain disturbing tendencies should be taken into account. Lithuanian exporters are not in the possession of trade marks recognized on the main foreign export markets, subsequently, have less opportunities, except in the CIS markets, for exporting products of higher value added. Unprocessed agricultural products still make a significant part of Lithuanian export. Industrial cheese – a product of a considerably low value added – dominates in the structure of milk products. Such circumstances lead to lower prices paid for most types of production to Lithuanian farmers than to the farmers of neighbouring countries. Subsequently, it slows down technological renovation of farms, and may in the long-term perspective hinder the development of the sector due to the increased expenses of human resources.

Employment, labour efficiency and income. The increasing labour efficiency in agriculture and the growing income of farmers are the key factors for increasing the competitiveness of the sector in the long-term perspective.

Annual value added created during the period of 2004–2008 (including forestry and hunting) per annual work unit (AWU) increased from LTL 15,7 thousand to LTL 46,7 thousand, i.e. almost by 3 times, and in 2008 in comparison to 2007 – by 1.4 times. Efficiency indicators in Lithuanian agriculture are still behind the average of the EU-15 and the EU-27 member states. Value added created in 2007 in Lithuania per AWU in the sectors of agriculture, hunting and forestry accounted for 44% of the corresponding indicator in the EU-15, and for 82% in the EU-27.

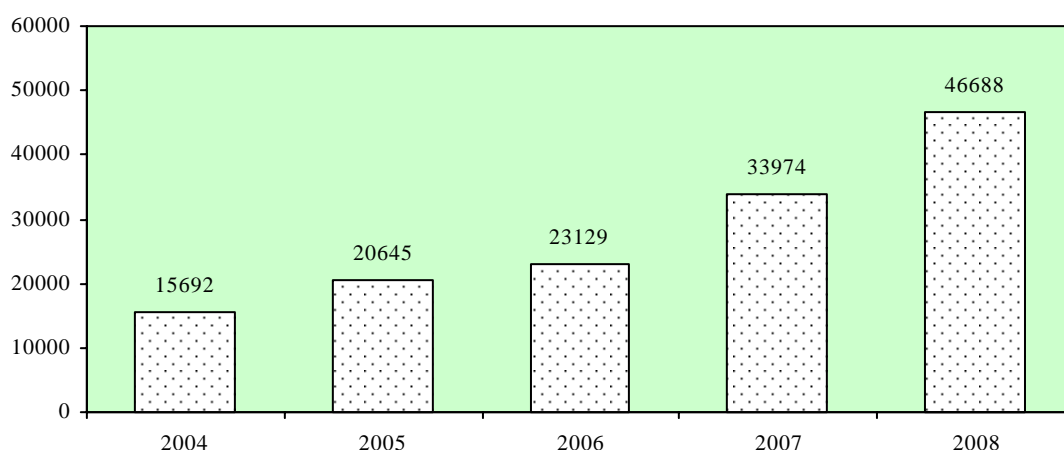

Fig. 1.2. Value added per annual work unit (AWU) in 2004–2008, in Litass

Source: data of the Department of Statistics to the Government of the Republic of Lithuania

The growth of labour efficiency in agriculture was influenced by the rapidly decreasing number of employees in the sector of agriculture. In 2008 the number of employed population in Lithuania amounted to 1 520,0 thousand, or 1.0% less than in 2007, however, by 5.8% more than in 2004.

The number of employed persons in agriculture, hunting and forestry was continuously decreasing during the entire reference period. Such declining tendency was influenced by natural demographic changes, large emigration and measures provided in the Lithuanian Rural Development Plans of 2004–2006 and 2007–2013 for early retirement withdrawing from commercial agricultural production. In 2008 the number of employees in the sectors of agriculture, hunting and forestry amounted to 116,6 thousand, by 25.7% less than in 2007, and by 48.3% less than in 2004. The number of employed persons in agriculture, hunting and forestry in 2008 accounted for 7.7% of the total number of employees in the country, i.e. by 2.5 per cent point less than in 2007, and by 7.0% less than in 2004. Changes on the labour market of Lithuania indicate that employment structure in Lithuania is getting closer to the structure characteristic of post-industrial countries, however, the role of this sector on the Lithuanian labour market remains significant and is considerably higher than the corresponding EU-15 indicator. In 2008, as compared with the EU-27, the share of population engaged in agriculture, hunting and forestry accounted for 3.3 per cent points, and in comparison to the EU-15 member states – by 4.5 percentage points higher. The declining tendency of employment is assessed positively on the one hand, as the figures are too high, and negatively on the other hand, as the process is taking place on the account of skilled employees.

The number of AWU in the sector of food, beverages and tobacco industry remained stable during the period of 2004–2008. According to the preliminary data of 2008 the number of AWU in the sector was 44,3 thousand, i. e. 4.1% of the national AWU average. Labour efficiency in the sector of food, beverages and tobacco was rapidly increasing: from annual value added of LTL 48,9 thousand per AWU in 2004 to LTL 78,8 thousand in 2008, i.e. even by 1.6 times.

However, labour efficiency in this sector as in the sector of agriculture is far behind the average of the EU-27 and the old EU member states.

Favourable tendencies in agriculture influenced rapid increase of farmers' income. In 2008 the average disposable monthly income of farmers' households per one member of the household amounted to LTL 1 139, and slightly exceeded the average income of urban population, exceeding significantly the average income of the entire rural population. During the period of 2004–2007 the disposable income of farmers' households increased by 2.8 times, and of the rural population – by 2 times. Such growth was influenced by the improved conditions for agricultural activities: more support, larger and updated farms, more favourable trading conditions, the increased demand in agricultural products, and as from 2007 – particularly advantageous prices on agricultural products.

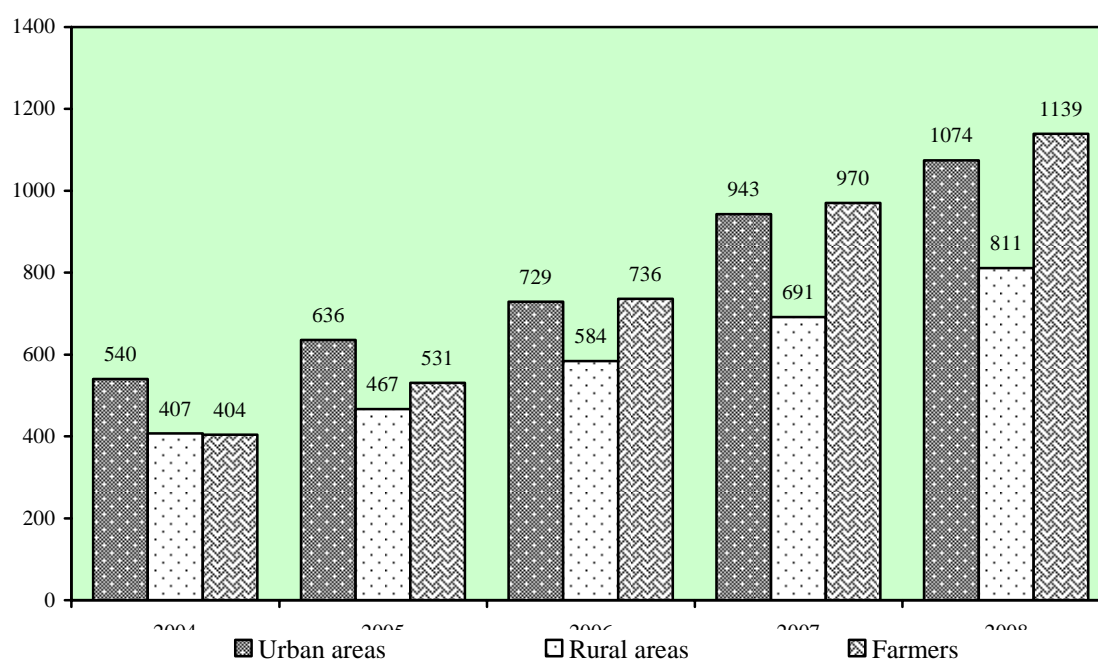

Fig. 1.3. Average monthly disposable household income per capita in 2004–2008, in Litas

Source: Data of the Department of Statistics to the Government of the Republic of Lithuania

Wage was also rapidly increasing in the sector of agriculture, hunting and forestry. Such tendencies were defined not only by the successful development of agriculture, but also by the general situation on the labour market – quick growth of wages in all spheres of the national economy and the decreasing level of unemployment until the last quarter of 2008. The average gross wage in the sector of agriculture, hunting and forestry amounted to LTL 1 637 in 2008, and was by 23.5% more than in 2007, and by 2 times more as compared with 2004. It should be noted that wage in the sector of agriculture, hunting and forestry was increasing more rapidly than on the average in the country, therefore the gap between the average monthly wage in the country and the wage in the sector of agriculture, hunting and forestry was decreasing. The average gross wage in the sector of agriculture, hunting and forestry in 2004 accounted for 70.1% of the national average, and in 2008 – for 72.6%.

Preconditions for the growth of labour efficiency in the sector of agriculture and food industry were created by investments from own means of economic entities and from the EU support funds. According to the data of the Department of Statistics, material investments into the sector of agriculture, hunting, forestry and fisheries in 2008 only by legal entities amounted to LTL 564,3 million, increasing by 85.8 times in comparison to 2004, and by 21.7 times in comparison with 2007. Material investments in the food industry increased by 53.2% during the period of 2004–2008. According to the data of the Farm Accountancy Data Network (FADN), provision for capital by commercial farms during the period of 2004–2007 per one ha of utilised agricultural area (UAA) increased by 1.8 times. However, the small-scale land management formed because of the land restitution to previous owners, hinders farmers from taking the advantage of the investments aimed in particular for the acquisition of modern equipment. Among the key issues to be addressed aiming at further growth of labour efficiency in the sector of agriculture is the improvement of the structure of land management.

Summarising the tendencies in the development of agriculture during the period of 2004–2008, it may be stated that this sector was among the most dynamic sectors of economy in Lithuania during the first five years of membership in the EU. Though the share of the created gross value added within the national value added was gradually decreasing alongside with the number of persons engaged in agriculture, the sector of agriculture and food industry retained its potential on the most important export markets due to the increased volume of production and the improved quality of products, and remains important in the face of the crisis in safeguarding the stability of the national economy

2. EU and national support and its impact on the development of agricultural and food sector in Lithuania

In 2004, when Lithuania joined the EU, funding of agriculture has considerably increased – new direct and investment support instruments were introduced, and national state support measures reorganised. The share of means in the Lithuanian budget allocated for the funding of agriculture increased by 2.16 times – from LTL 1 359,9 million in 2004 to LTL 2 930,7 million in 2008, including LTL 477,7 million and 1 587,6 million correspondingly from the EU funds.

By the end of the 2004–2006 period for the implementation of the Single Programming Document (SPD), the 2007–2013 Rural Development Programme (RDP) of Lithuania was approved in 2007. The new programme covers 4 programming Axes consisting of 25 measures. Action programme for the same period in the fishery sector was also approved in 2007 for the follow-up of the previous measures introducing accordingly new support measures. In 2007, by the end of the transitional period, the content of state support measures has changed updating the principles of granting direct payments from the national budget – some payments were dissociated from manufacturing in the current year and paid for crops, animals or the amount of sold milk in the reference period.

In 2008, following the identified new demands, rules for granting support were adjusted according to the measures defined in the Lithuanian 2007–2013 RDP, updating

accordingly the procedure for export refund payments; discussions of the guidelines of the EU common agricultural policy (CAP) started; and new draft laws were adopted. Subsequently, such changes in agricultural policy will influence accordingly the conditions and the scope of further support to producers of agricultural and food products, administrative provisions and coherence.

Direct payments and market regulation measures. The so called scheme of Lump-sum payments for land areas was adapted in Lithuania since 2004, according to which direct payments were granted from the EU budget means for good condition UAA, and additional national direct payments were allocated from the state budget for grain crops, rapeseed, fibre flax, legume crops, protein and energy crops, perennial herbs for seed and fodder crop mix, also for bulls, suckler cows, slaughtered adult cattle, ewes, quota milk and sugar. The level of direct payments was annually increasing until 2008 (Fig. 1.4). The total amount of the EU and the national support paid to Lithuanian farmers in 2008 for the declared UAA, animals and milk was LTL 1 094,6 million, including LTL 667,5 million of direct payments from the EU budget (LTL 409,5 million in 2004), and LTL 427,1 million from the state budget for additional national direct payments (LTL 192,5 million in 2004).

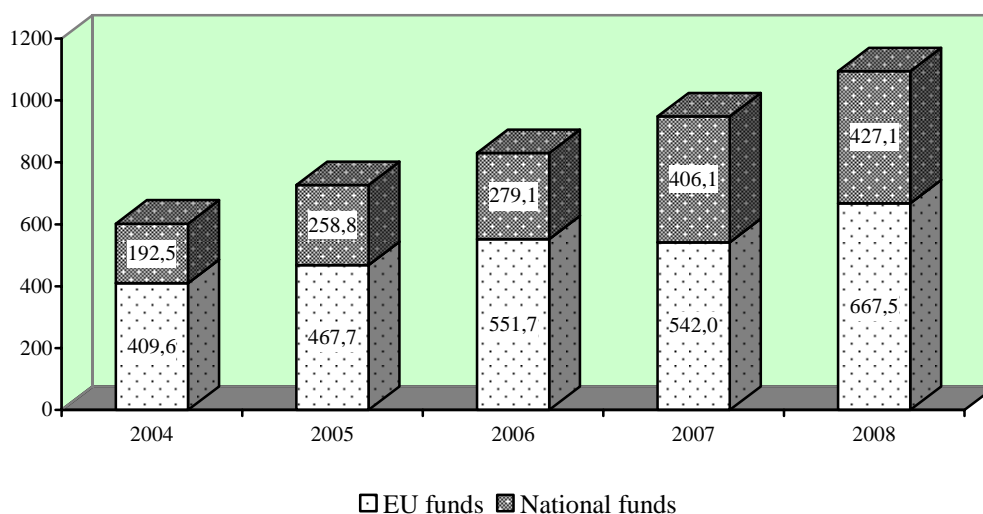

Fig. 1.4. Funds for direct payments in 2004–2008, in million Litass

Source: Data of the National Paying Agency

Gradual implementation of the principle of separating the national part of support from manufacturing started in Lithuania in 2007. Additional national direct payments are only partly related to the scope of production in the year of submitting applications, and the amount of the remaining part of the payment depends on the actual scope of production in the reference period. Reference period for defining the scope of production differs by the type of the supported object: for grain crops, rapeseed, flax and protein crops – the area of crops in 2006; for bulls – the average number of bulls, for which the extensivity payment was granted, and which were kept by the applicant during the period of 2004–2006; for suckler cows – the number of suckler cows answering the support requirements and kept before 31 March 2007; for slaughtered

cattle - the average number of cattle delivered for slaughtering in 2004–2006; for ewes – the average number of ewes kept in 2004–2006, and for which the support was paid; for milk – the amount of milk delivered in the quota year of 1 April 2006–31 March 2007.

In 2008 in the face of the increasing general level of support for direct payments, the amount of additional direct payments varied unevenly – support for crops was reducing, and for livestock production – increasing (Table 1.2). Considering the unfavourable market situation in 2008 additional national direct payments for milk were increased up to the highest admissible level of direct payments – from the planned 53 Lt/t to 87 Lt/t. Moreover, such payments were disbursed in September before the end of the set payment term.

Table 1.2. Direct payments in Lithuania in 2004–2008

Kind of payment	2004	2005	2006	2007*	2008*
Basic payment, Lt/ha	111	140	169	198	248
Quota sugar payment, Lt/t	-	-	219	269	318
Additional payments for production:					
grain crops, rapeseed, Lt/ha	196	195	195	170	144
protein crops, Lt/ha	196	274	275	256	251
fibre flax, Lt/ha	463	446	415	392	348
perennial herbs for seed and fodder crop mix, Lt/ha	-	-	-	170	100
energy crops Lt/ha	-	-	-	170	144
suckler cows, Lt/head	500	559	559	559	610
bulls, Lt/head	510	552	552	551	593
slaughtered adult cattle, Lt/head	89	193	193	193	250
ewes, Lt/head	30	42	42	48	53
quota milk, Lt/t	110	48	48	53	87

*The amount of given additional national direct payments in 2007–2008 indicate the sum of coupled and decoupled payments.

Source: Data of the Ministry of Agriculture

After joining the EU Lithuania started receiving Export refund payments from the EU budget for the exported production into third countries. Such payments were granted for meat, grain, milk and some other products. Most of export refund payments were disbursed in 2006 – even up to LTL 216 million. Key amendment in the CAP of 2008 was the decision of the European Commission to discontinue export refund payments for milk and milk products, sugar and grain sector products, subsequently, the total amount of export subsidies decreased from LTL 98 million in 2007 to LTL 29 million in 2008.

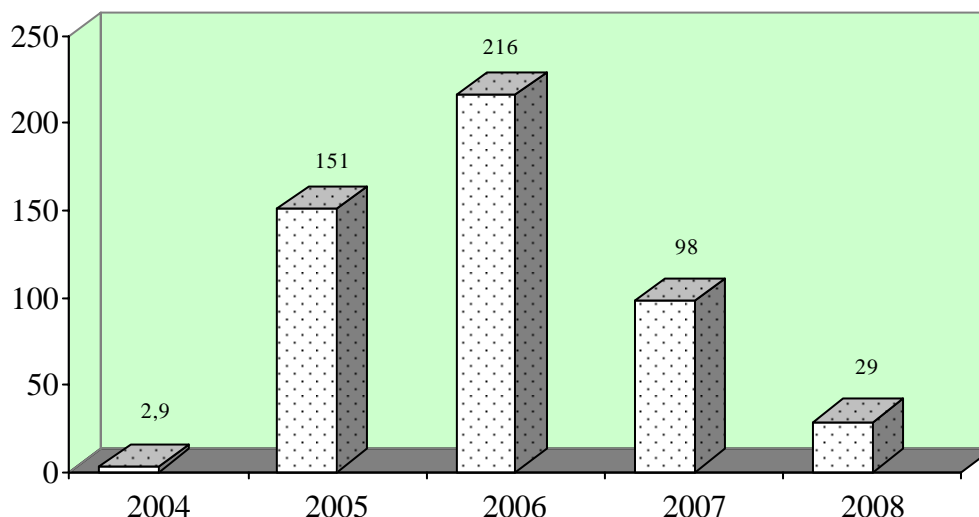

Fig. 1.5. Funds for export subsidies in 2004–2008, in million Litass

Source: Data of the National Paying Agency

Most of subsidies in 2008 were received by companies, which exported meat products (LTL 24 million). Income from subsidies for exporting milk products decreased more than by 70% in comparison to 2007, as the disbursement of such payments was discontinued from May 2008. Trade in milk products on the internal market increased by 14% in 2008, but by 5.7% less of milk products than in 2007 were exported. Moreover, export directions have also changed – more of the production is exported to the EU, and less to the third countries. Substantial reduction and withdrawal of export subsidies influence the scope of production in the sector of agriculture and food industry, lowering the interest in exporting, making negative impact on producers in the sector of agriculture and food industry in deciding to develop farms and holdings, as well as applying for support aimed at upgrading the production or increasing the value added of products.

Another instrument of market regulation in the CAP is intervention purchase – state procurement of agricultural production by purchasing the surplus amount aimed at keeping market prices and safeguarding in such a way agricultural entities from failure. Such procurement is funded as from the EU as from the national budget means. The scope of intervention purchase is irregular every year, depending on the level of market prices. Most of intervention purchases from the day of membership in the EU were made in 2006 – LTL 24,5 million for the funding of such measures were used from the EU budget, and LTL 7 million – from the national budget. Mostly grain – wheat and barley - are delivered to intervention stores. During the period of 2007–2008 less production was purchased for intervention due to the increased purchase prices on agricultural production.

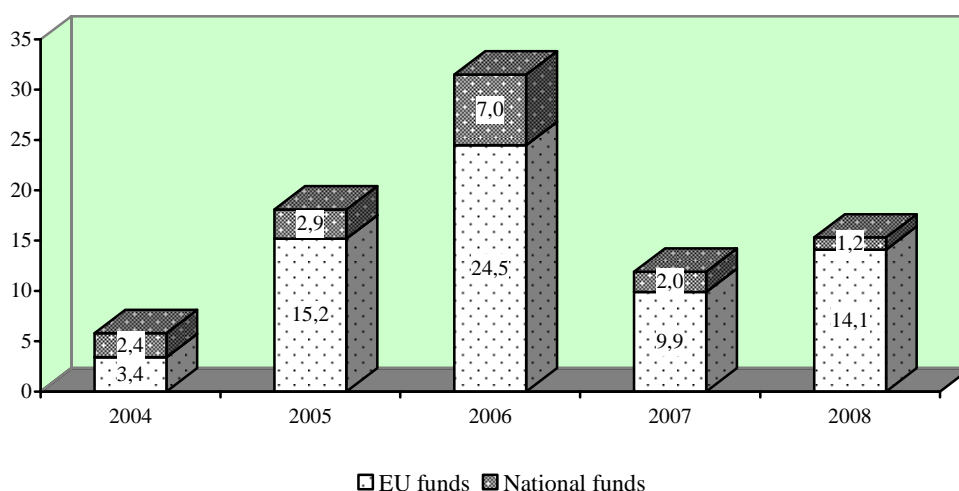

Fig. 1.6. Funds for intervention purchase in 2004–2008, in million Litass

Source: Data of the National Paying Agency

Rural development measures. The new programming period started in 2007, during which obligations undertaken in the signed agreements under the 2004–2006 SPD and 2004–2006 Rural Development Plan support measures will be further implemented, starting alongside the implementation of the new envelope of measures under the RDP for 2007–2013.

Funding allocated for the period of 2007–2013 amounts to LTL 7 483,8 million (Table 1.3).

Table 1.3. Funds for rural development measures in 2007–2013

Measure	Allocated funds, mill. Lt	Share in total funds, %
Modernisation of agricultural holdings	1386	18,52
Agri-environment payments	1260	16,84
Payments to farmers in areas with handicaps	991	13,24
Early retirement	577	7,71
Processing of agricultural products and increasing of value added	475	6,34
Implementation of local development strategies	438	5,86
Support for business creation and development	337	4,51
Encouragement of rural tourism services	284	3,80
Diversification into non-agricultural activities	261	3,49
Setting up of young farmers	215	2,87
First afforestation of agricultural land	204	2,73
Improving and developing infrastructure related to the development and adaptation of agriculture and forestry	203	2,71
First afforestation of non-agricultural land	157	2,10
Consulting services	126	1,68

Measure	Allocated funds, mill. Lt	Share in total funds, %
Semi-subsistence farming	103	1,38
Support for Natura 2000 territories	88	1,18
Improvement of economic value of forests	71	0,95
Rural renewal and development	69	0,92
Vocational training and information actions	57	0,76
Restoring forestry potential	52	0,69
Non-productive investments into forests	35	0,46
Forest environment payments	35	0,46
Natura 2000 payments linked to directive 2000/60/EC	26	0,35
Support for running the LAG	20	0,27
Interregional and international cooperation	14	0,19
In Total	7484	100,00

Source: Data of the Ministry of Agriculture

Due to the delay in approving the new programme, the implementation of only some measures started in 2007: support to farmers engaged in agricultural activities in the areas with handicaps, other than mountain areas, agri-environment and Natura 2000 payments, related to the Directive 2000/60/EC. The implementation of measures in 2008 became more intensive. About LTL 1 120 million of the support was granted for the implementation of measures in 2008, i.e. approximately 17% of the total amount allocated for 2008–2013, including LTL 862 million from the European Agricultural Fund for Rural Development. Most of the support – 49% of the total amount - was allocated for the implementation of measures under Axis I (improvement of competitiveness in the agricultural, food and forestry sector). Aiming at improving the competitiveness of farmers, possibilities will be created for modernizing agricultural holdings and increasing value added of agricultural products – planned payments for the interested entities account for approximately 54% and 13% accordingly of the allocated subsidy under Axis I (processing enterprises may also be the beneficiaries of the subsidy). The process of agricultural restructuring related to the competitiveness of the country is encouraged through successive measures: set up of young farmers (12.6% of the subsidy under Axis I), and early retirement of senior farmers from commercial agricultural production (0.2%). Much attention will be further given to the issue of equalizing income disparity, arising from different farming conditions. Over 19% of the total amount of means allocated for the 2007–2013 RDP are scheduled for agricultural holdings in less favourable areas. Environmental measures become more and more important and are correspondingly more intensively funded. 26% of the total annual funding in 2008 was scheduled for the environment and landscape improvement measures, while for the entire programming period – 36.5% of the total amount of the subsidy.

Allocation and disbursement of the subsidy following the submission of applications under most of the RDP measures takes time because of assessment procedures, therefore a significant part of allocated means in the current year are paid during a few subsequent years, and the amount of the subsidy paid in a particular year should be considered as a summarised subsidy of several years. Almost LTL 300

million of the subsidy was paid in 2008: the largest amount of 53% – for farmers engaged in agricultural activities in less favourable areas, 20.7% for young farmers, and approximately 12% as agri-environment payments.

Administration of the implementation of measures under the 2004–2006 SPD for Lithuania and the 2004–2006 RDP is further continued. In 2008 the following payments were made by applications received during 2004–2006: LTL 304,4 thousand under RDP measures, and LTL 140 thousand – under SPD measures.

It is difficult yet to assess the efficiency and the benefit of the implementation of measures under the new Rural Development Programme, however, referring to the indicators on the implementation of the granted subsidy in previous periods, subsidy, granted for the implementation of rural development measures, in comparison to other types of support, is among the most oriented towards a particular outcome and among the most efficient.

State support. The level of funding state support measures is annually increasing. In 2008 the state support from the national budget amounted to LTL 112 million. The largest part of means, as in previous years, was granted for the development of the breeding system. Though from the middle of 2007 subsidy for the acquisition of pedigree animals is discontinued, further support is provided for the supervision of breeding and for the improvement of the quality of production, aiming at safeguarding the competitiveness in the EU.

A substantial part of national support was granted for covering insurance contributions and for compensating loan interests – 17% and 12% correspondingly (Fig. 1.7).

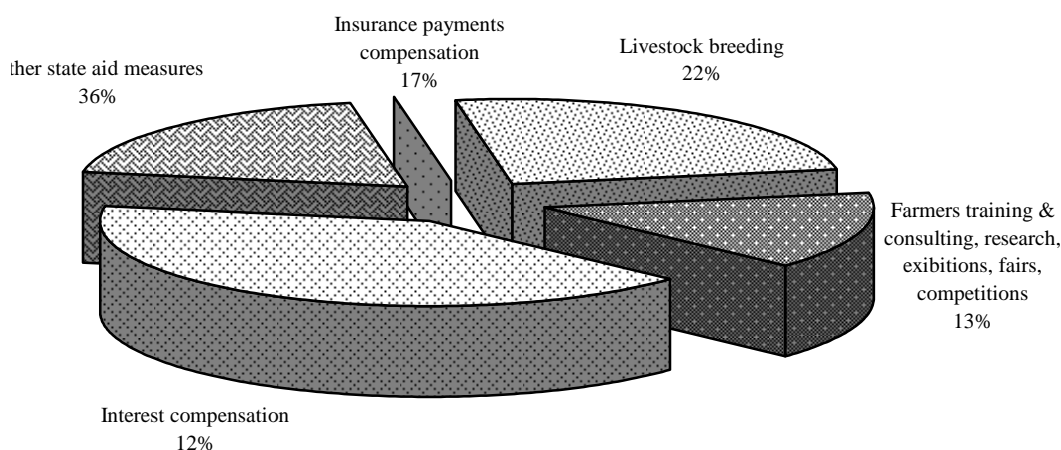

Fig. 1.7. Structure of state-financed measures in 2008

Source: Data of the Ministry of Agriculture

By the end of 2007, following the introduction of the system of insurance of crops, over LTL 14 million was allocated for compensating insurance contributions, approximately LTL 29 million was scheduled for 2008, but only some LTL 19 million were actually absorbed. The insured area of crops in 2008 was 70 thousand ha, and the sum of insurance – about LTL 135 million. Irrespective of the small part of the insured crops, farmers started using more actively insurance services and support provided by the state – the area of insured winter crops in 2009 amounts to 58 thousand ha, while in 2008 it has only reached 20 thousand ha.

At the beginning of the new programming period (2007–2013) participation in the support programmes became more intensive, as well as taking loans by agricultural holdings and using state support for compensating loan interests. In 2008 support provided for compensating loan interests amounted to almost LTL 13,5 million.

In 2008 four new state supported aid measures were introduced: compensation of a certain part of insurance losses for insurance companies in covering insurance for the damage incurred through natural droughts (LTL 7,5 million); support in purchasing second-hand equipment in the flax sector (LTL 0,1 million); support for beekeeping (LTL 1,8 million); and compensations to land managers and owners for the limitation of activities set by public institutions in the protected territories (LTL 1 million).

Since the middle of 2007 state support under the measures “Support for the acquisition of pedigree animals” and “Support for the acquisition of certified plant multiplicative material” was discontinued. Withdrawal of the latter aid had almost no impact on the amount of the acquired multiplicative material and the related actions, while the withdrawal of support for pedigree animal breeders had a significant negative impact. It is difficult to start or develop business in pedigree animal breeding, in particular cattle, without any support, because of big initial investments and a long buying off period

Measures for encouraging the development of the fisheries sector. In 2008 measures for the development of the fisheries sector under the 2004–2006 SPD of Lithuania were further implemented. As in the sector of agriculture, the new programming period of this sector started in 2007, granting the support under the 2007–2013 action programme for the Lithuanian sector of fisheries covering four priority guidelines.

One of the key goals in granting subsidies is to match fishing capacities with fish resources. In achieving this goal part of the fishing vessels will be upgraded, disposing of some other vessels by stopping their activities. Key directions for support are the following: modernization of aquaculture and processing enterprises, the development of the fishing harbour and piers, measures aimed at mitigating social consequences and the environment.

In 2008 calls for submitting applications were organised under 4 measures: discontinuation of activities of fishing vessels altogether (19 applications received asking for support in the amount of LTL 11,3 million), aquaculture (4 / LTL 3,8 million), fishing in inland waters (24 / LTL 32,6 million), and collective actions (4 / LTL 2,2 million).

Positive tendencies in the sectors of agriculture, fisheries and food industry of Lithuania may be clearly traced – agricultural holdings are enlarged and upgraded, quality of production is improving, more investments are made for increasing value added, also tendencies in observing environmental requirements and the development of

sustainable farming are obvious. Diversification of activities in rural areas is slowly increasing and the quality of living of rural population is improving. The implementation of agricultural and rural development policy measures had a great impact on such changes. During the new programming period accessibility to the support is extended through the wider scope of subsidized areas and through the enlarged funding. Subsequently, it may be presumed that the implementation of such measures will have a positive impact on increasing the competitiveness of agricultural holdings, on rural development, and on the improvement of the life quality of rural population.

II. LITHUANIAN AGRICULTURAL AND FOOD SECTOR IN THE SINGLE MARKET

1. Changes in the trade of agricultural and food products on the domestic market

Five years of membership in the EU influenced further the formation and the development of new conditions on the domestic market of the country, which had a great impact as on local consumers, as on producers.

Domestic market for consumers became the place for choosing wide scope and continuously diversifying natural and processed agricultural and food products, where a particularly ample variety of vegetables, fruit and berries is presented. Choice of meat and dairy products was also diversified leading to the change in prices depending on alternations of tendencies in demand and supply, and shifting purchasing capacities of consumers.

Domestic market raised certain problems for producers and sellers of agricultural and food products. Lithuanian domestic market was naturally shrinking: the number of population was decreasing as well as the real income. However, the reduction of real income of the population and inflation processes did not reduce the demand in products satisfying physiological needs of people; actually such expenditure of the population was increasing by reducing expenditure on other needs. Moreover, people started choosing the supplied agricultural and food products more attentively. This forced producers and sellers consider the requirements of consumers, which necessitated additional efforts and costs.

Local inhabitants and sellers understood that joining of the Lithuanian domestic market into the single market of the EU opened the gates to Lithuania for producers and sellers of similar products from other countries – the EU member states. This induced local producers to join the battle of competition. Local producers and sellers could compete on domestic markets of other countries as well, which increased costs for supplying their goods to consumers, and reduced purchase prices for raw products.

Large commercial networks have increasingly covered production and outlet markets in agricultural and food products, imposing their terms and conditions on producers of crude products and processors. Processing undertakings have been also forming their monopolistic associations.

Other factors were also influencing the acuteness of these problems. In 2006–2007 prices on milk, bread and meat increased leading to the increased production of such products. In 2008 good harvest of grain crops, potatoes, vegetables and fruit amounted to surplus of such products leading to the drop in prices. Producers of livestock products could purchase cheaper feedstuffs.

Changes in prices on the first line of production had only little impact on processors and sellers of agricultural products, who established oligopolistic structures, resulting in the lowest purchase prices of agricultural raw products in Lithuania, and the highest prices of processed products in comparison to corresponding prices in many other EU member states.

The average consumption level of food products by Lithuanian population is close to the EU average. Over one third of a family budget is spent on food products; therefore, everybody is sensitively reacting to any inflation processes.

According to the data of the Lithuanian Department of Statistics, the annual inflation level in December 2008 reached 8.5%, and the growth in prices on food products and soft drinks – 10.9%. Prices on meat and meat products increased most within a year – by 22.1%, on bread and grain products – by 15%. Only prices on milk and dairy products, cheese and eggs, dropped by 3.6% per year. The structure of consumption expenses did not change much, as the average wage of employees in the national economy increased by more than 20%.

In 2008 the demand on the domestic market and in export induced the production and purchase of agricultural products (Table 2.1), however, were not as successful as in the year of 2007.

Table 2.1. Production and purchase of agricultural products in 2004–2008, in thou. tons

Indicators	2004	2005	2006	2007	2008	2008 compared to 2004, %
Production						
Livestock & poultry, slaughtered (live weight)	303	323	335	350	293	97
Milk production	1849	1862	1891	1937	1884	102
Egg production, mill. pieces	863	864	929	920	950	110
Grain production	2917	2870	1893	3073	3484	119
Purchase						
Cereals	1403	1760	1149	1774	2406	171
Rapeseed	173	215	137	330	299	173
Sugar beet for industry	905	798	716	800	339	37
Potatoes	21	11	12	17	49	233
Vegetables	34	28	31	42	56	164
Fruit & berries	14	72	80	57	40	286
Livestock & poultry (live weight)	200	211	252	271	243	122
Natural milk	1140	1200	1281	1389	1376	135
Milk (equivalent of base fatness)	1371	1432	1539	1630	1661	121
Eggs, mill. pieces	486	487	482	461	454	93

Source: Data of the Department of Statistics to the GovRL

The share of trade of Lithuanian producers in agricultural and food products on the domestic market of Lithuania (Table 2.2) indicate that producers of milk, cattle and poultry, as well as fruit and berry processors are very much dependant on the situation of external markets.

Table 2.2. The share of sales of major food products of Lithuanian producers on the domestic market in 2008, in per cent

Food products	Share of sales, %
Dairy products	46,4
Beef	29,3
Pork	94,8
Poultry meat	77,2
Meat products and sausages	94,6
Eggs	70,0
Rye bread	96,5
Wheat bread	91,8
Wheat flour	95,1
Rye flour	94,0
Cereal groats	73,1
Pastry and confectionery	96,5
Potato products	44,8
Fruit and vegetable products	59,9

Source: Department of Statistics to the GovRL

The volume of sales in food products is annually increasing (Table 2.3).

Table 2.3. Retail sales of food products, alcoholic beverages and tobacco in 2004–2008, in million Litas

Economic activity	2004	2005	2006	2007	2008
Retail sales in food products, alcoholic beverages and tobacco	7239,1	7978,7	8903,5	10555,3	12499,2
per capita, Lt	2101	2337	2623	3127	3722

Source: Department of Statistics to the GovRL

2. Tendencies of foreign trade in agricultural and food products

According to the preliminary data of the Department of Statistics to the Government of the Republic of Lithuania (April 2009), Lithuania exported agricultural and food products in 2008 for LTL 8 876 million (by 20.8% more than in 2007), and imported for LTL 8 105 million (by 32.9% more). Trade balance remains positive since 2005, however, in comparison with 2007, it reduced to LTL 771 million in 2008 (in 2007 it was 1.6 times higher and amounted to LTL 1 248 million). Foreign trade turnover increased more than by 24% (Fig. 2.1).

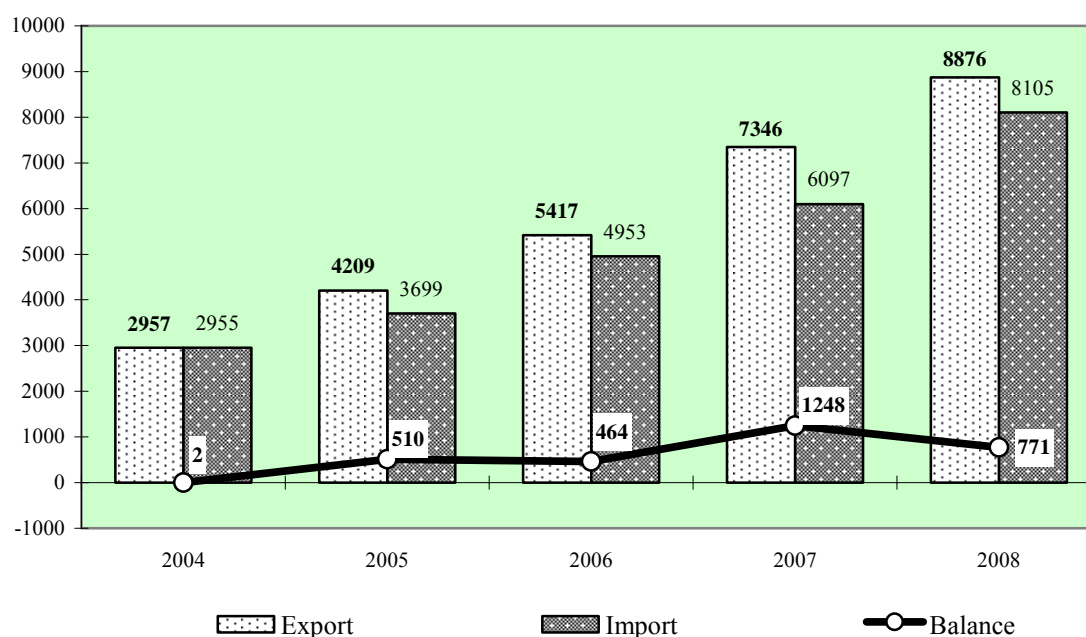

Fig. 2.1. Export, import and foreign trade balance of agricultural and food products in 2004–2008, in million Litai

Source: Department of Statistics to the GovRL

Trade in agricultural and food products is covering annually a larger proportion in the total foreign trade of Lithuania (Table 2.4). In 2008 export in agricultural and food products accounted for 16.0% of the total export of goods, and import – for 11.2% of the total import (in 2005 correspondingly for 12.9% and 8.6%). Presumably, that in the face of the crisis, when consumer commodities are more in demand, trade in agricultural and food products will cover even a larger part of the total foreign trade of Lithuania.

Table 2.4. The share of trade in agricultural and food products in the total foreign trade of Lithuania in 2005–2008

Year	Lithuania's foreign trade, mill. Lt		Trade in agricultural and food products, mill. Lt		Share of trade in agricultural and food products, %	
	exports	imports	exports	imports	exports	imports
2005	32767,3	43151,9	4208,8	3699,1	12,8	8,6
2006	38888,3	53274,6	5416,6	4952,8	13,9	9,3
2007	43234,3	60987,4	7352,4	6071,8	17,0	10,0
2008*	55477,4	72593,2	8876,0	8105,2	16,0	11,2

* Preliminary data.

Source: Department of Statistics to the GovRL

In 2008 the structure of export has changed (Fig. 2.2). Most of the export in 2007 consisted of prepared foodstuffs, beverages and tobacco products of the CN sector goods (Section IV), and in 2008 – of vegetable products (Section II). Export of such

goods increased by more than 1.5 times. Export of goods from Section IV increased by 9.2%. The third largest group of exported goods (by 1.3% more) consists of live animals and products of animal origin (Section I). Though, in comparison to other goods, export of fat and oil (Section III, CN 15) decreased, export value in 2008 was by 1.7 times higher. Products of Lithuanian origin covered the largest part in the export of goods of Section I – 91%; in Section IV – 74%, in Section II – 50%, and in Section III – only some 41%.

The structure of import (Fig. 2.2) has not changed. As in 2007, most of imported goods in 2008 consisted of prepared foodstuffs, beverages and tobacco products, amounting to LTL 3 022 million. In comparison to 2007, import of the above goods increased almost by 1.3 times. Import of products of vegetable origin was next and increased by more than 1.5 times, and in the third line of import were products of animal origin, the value of which amounted to LTL 1 847 million with 18% increase. Import of vegetable fats and oils increased most – by 64%.

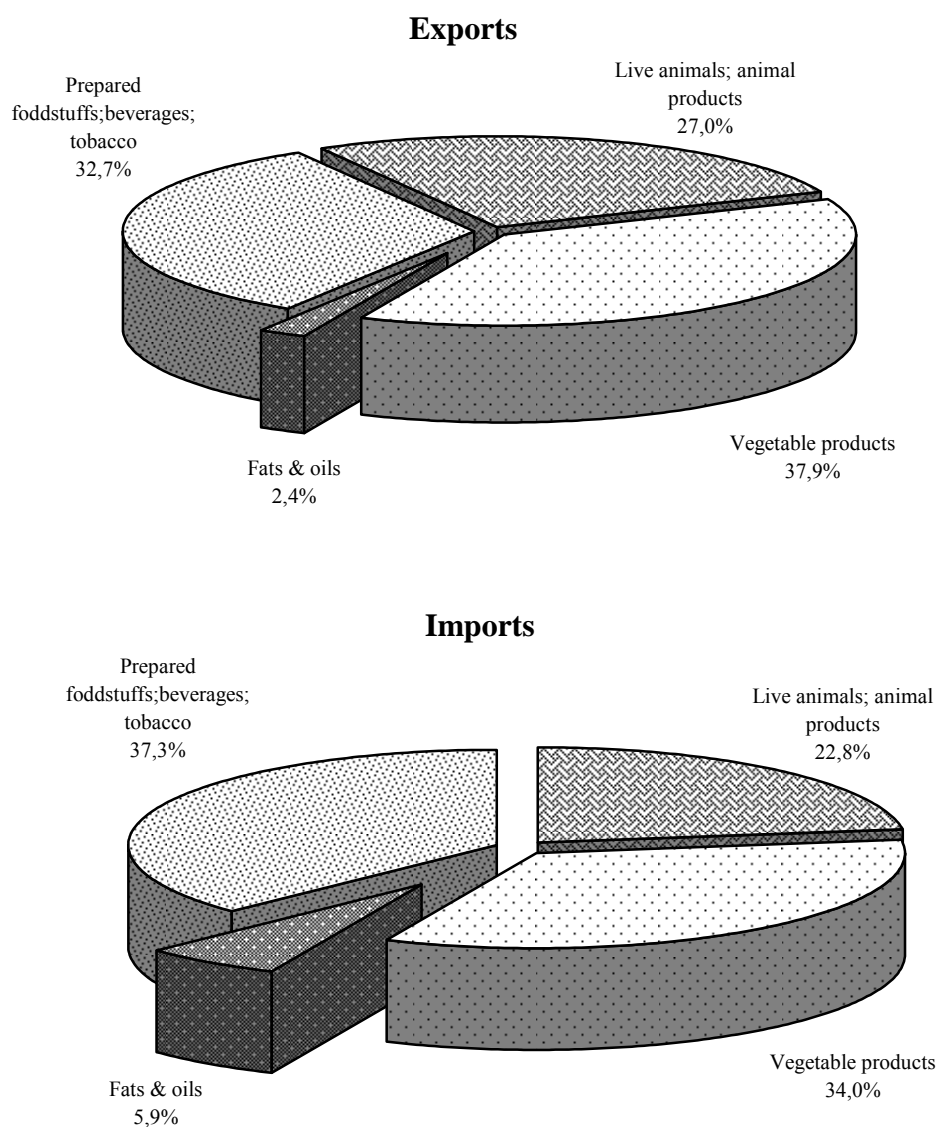

Fig. 2.2. Structure of export and import of agricultural and food products in 2008

Source: Department of Statistics to the GovRL

In 2008 most of exported goods traditionally consisted of milk and dairy products – for LTL 1 272 million (ice-cream, casein and milk sugar exclusive), which accounted for 14.3% of the total value of export in agricultural and food products in 2008.

Though export of cheese and curd amounted to 68,3 thousand tons (by 21% more than in 2007), and the average price on these products increased from 10,85 Lt/kg in 2007 to 11,44 Lt/kg in 2008, prices and amounts of some exported dairy products significantly decreased. Export of non-concentrated milk and cream decreased by 1.3 times, and the average annual export price dropped by 1.2 times. The price on butter increased by 4%, but export of butter decreased by 1.4 times (5,8 thousand tons), resulting in the change of the export structure of dairy products: the share of cheese and curd increased from 49% to 61%, but decreased of concentrated milk products – from 17% to 14%, of whey – from 7.0% to 4.6%, and of butter – from 5.2% to 4.1%. Over 64% of dairy products were exported to Russia, Italy and Germany (34.9%, 17.6% and 11.8% accordingly). 59% of dairy products were exported into the EU countries.

99% of exported milk and dairy products in 2008 were of the Lithuanian origin. This percentage varied every year, but was never below 97%. Export structure of Lithuanian milk and dairy products during the period of 2004 – 2008 is given in Fig. 2.3.

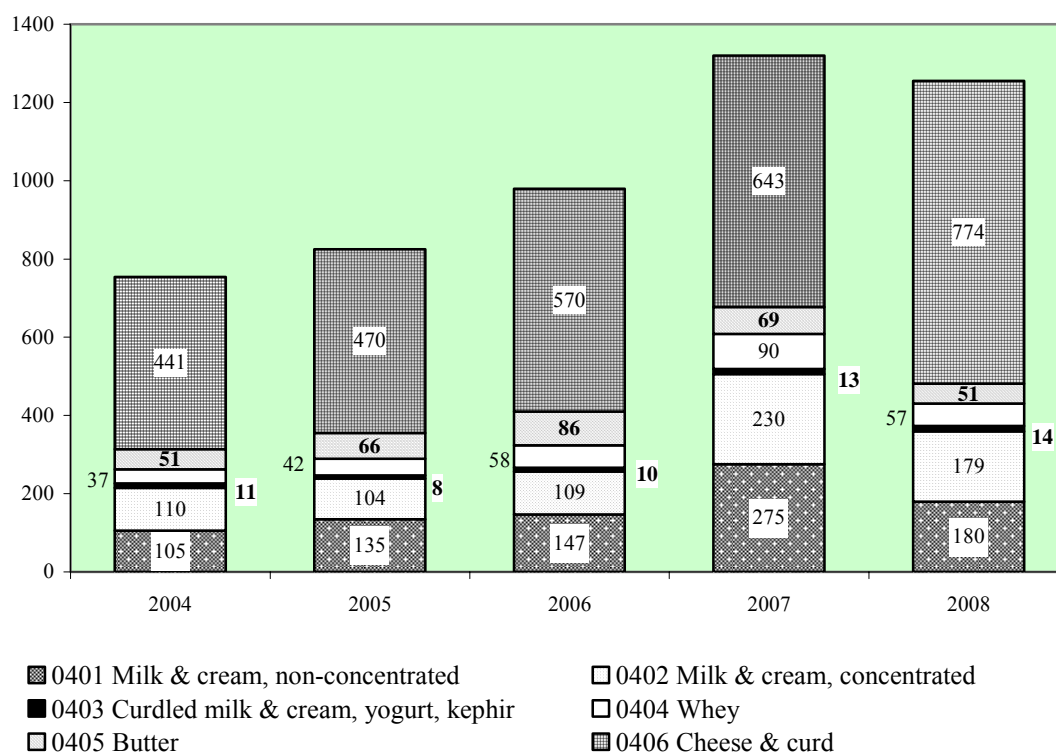

Fig. 2.3. Export structure of milk and dairy products of Lithuanian origin in 2004–2008, in million Litai

Source: Department of Statistics to the GovRL

Grain takes the second place by the export value. In comparison to 2007 grain export value increased by 2.1 times in 2008, amounting to over LTL 1 115 million. In total Lithuania exported 1 604 thousand tons of grain: 1 127 thousand tons of wheat, 316 thousand tons of barely, 60 thousand tons of rye, 48 thousand tons of buckwheat, 38 thousand tons of corn, 13 thousand tons of oats, and about 3 thousand tons of other sorts of grain. Export of wheat increased by 2.7 times in comparison with 2007, and the average price increased by 6% amounting to 726 Lt/t. Though export of barley increased by 39% as compared with the previous year, the price decreased by 1.4 times, resulting in almost unchanged export value. Export value of wheat accounted for 73%, of barely – for 16% of the total grain export value. 80% of wheat was exported to Algeria, Latvia, Morocco, Turkey, Oman, Poland, and Belarus; 87% of barley was exported to Saudi Arabia, Poland, Latvia, Denmark, and Syria. 59% of all grain was exported to third countries.

98% of grain exported in 2008 were grown in Lithuania. Grain export structure of 2008 is given in Fig. 2.4.

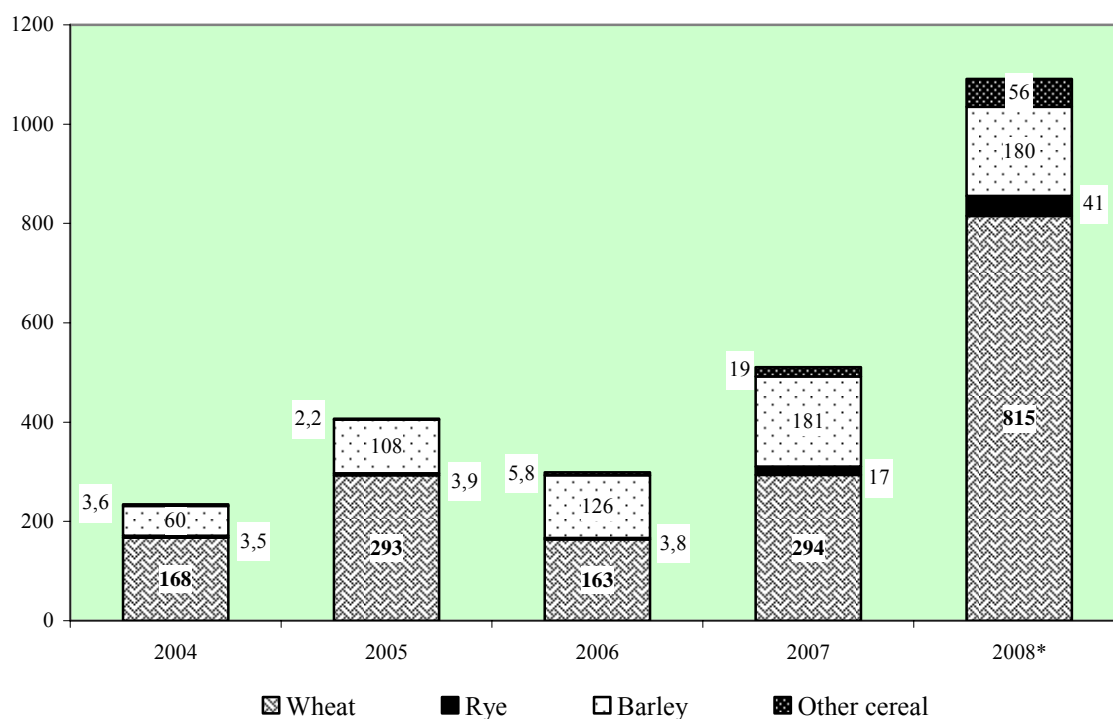

Fig. 2.4. Export structure of Lithuanian origin cereals in 2004–2008, in million Litass

Source: Department of Statistics to the GovRL

Fruit, berries and nuts are in the third place by export value (12.6% of the total export), amounting to LTL 965 million, by 1.3 times more than in 2007. Only 5.6% of exported fruit, berries and nuts were grown in Lithuania, other products were of non-Lithuanian origin. The largest part of export consisted of apples (202 thousand tons for LTL 340 million, accounting for 35% of fruit export), cherries and peaches (for LTL 130 million, and 14%) fresh (for LTL 101 million, 10%) and processed (for LTL 97 million, and 10%) berries. 75% of fruit and berries were exported to Russia.

A substantial part of vegetables was exported – for LTL 660 million, accounting for 7.4% of the total export; 87% of exported vegetables were of non-Lithuanian origin. Export of vegetables increased by 1.3 times in comparison to 2007. Major part of export of this production (80%) consisted of mushrooms, paprikas, tomatoes and cabbage. 75% of vegetables was exported to Russia.

Export value of waste from food industry and prepared feedstuffs for animals amounted to LTL 633 million, and accounted for 7.1% of the total export of agricultural and food products, resulting in 10% increase as compared with 2007. 57% of export consisted of feedstuffs for dogs and cats, 24% – of products used for feeding other animals, 8.0% – rapeseed cake. Main countries of export – the United Kingdom, Russia, Germany, Belarus, Poland, and Norway.

A substantial part of meat was exported (export value – LTL 448 million, 5.1% of the total export of agricultural and food products; increased by 6.8% in comparison to 2007), also meat products and fish (LTL 442 million / 5.0% and 23% correspondingly). Export of live animals increased: of live pigs – by 1.5 times (415 thousand heads exported, value increased by 1.8 times, amounting to LTL 163 million), of chicken – by 2 times (8 090 thousand of chicks, 2.4 times, LTL 17 million, correspondingly). Though the number of exported live animals decreased by 7.1% (144 thousand heads exported), export value increased by 4.6% amounting to LTL 96 million.

The share of meat and meat products prepared in Lithuania in 2008 accounted for 93% of the total export of meat and meat products. Export structure during the period of 2004–2008 is given in Fig. 2.5.

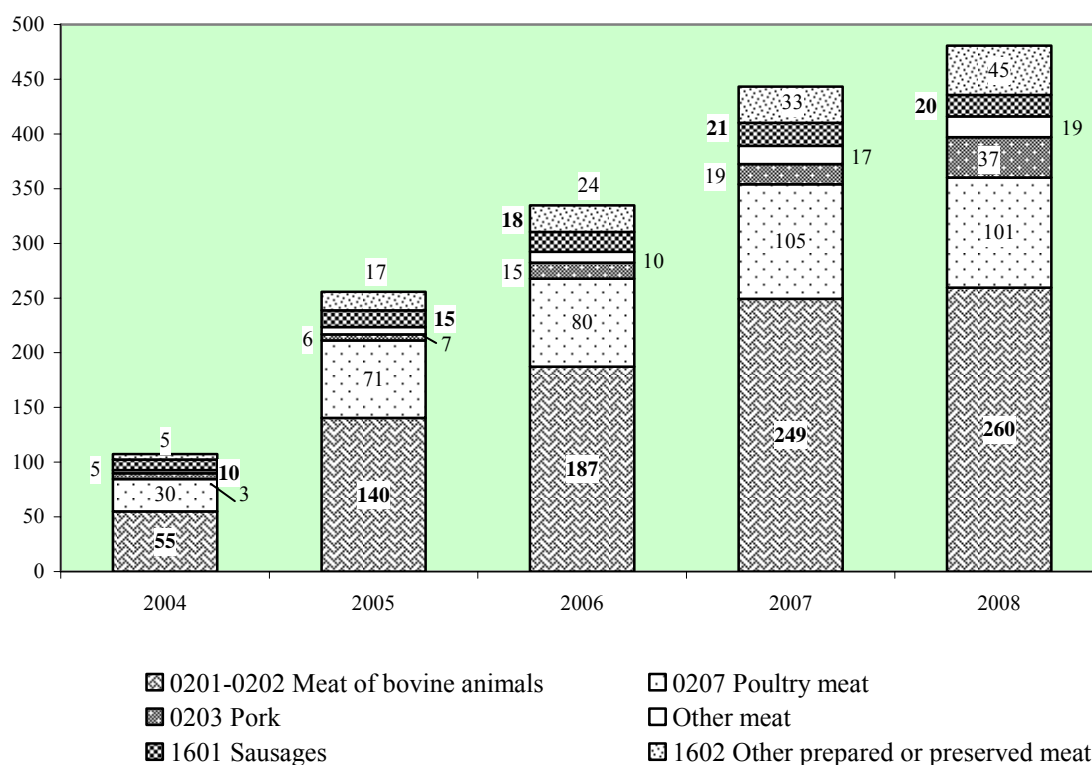

Fig. 2.5. Structure of exports of Lithuanian origin meat and prepared or preserved meat products in 2004–2008, in million Litass

Source: Department of Statistics to the GovRL

31% of exported products (including products with 50% of the value created abroad) are of non-Lithuanian origin. Almost all exported tobacco products (99.9%), dairy products (98.5%), live animals, grain (97.7%), ground products (97.3%), meat and fish products (94.5%), and meat (92.8%) are of the Lithuanian origin. In some groups of exported products goods of the Lithuanian origin accounted for less than 50%: fruit – only for some 6% of the total export of this product; coffee, tea and spices – 12%; vegetables – 13%; various food product groups (CN 21 goods) – 28%; soft and strong drinks – 31%; fats and oils – 41%. Export value of products of the Lithuanian origin into the EU-27 states accounted for 81%, and into third countries – for 53% of the total value of exported products into these countries.

In 2008 import of agricultural and food products into Lithuania amounted to LTL 8 105 million, by 33% more than in 2007. Import growth rate exceeded that of export. Of 24 product groups only import of ground products, tobacco and its products, and products of animal origin not suitable for human food decreased.

Traditionally, most of fruit and nuts were imported (for LTL 1 218 million, 15% of the total import of agricultural and food products, increased by 1.4 times). A substantial amount of soft and strong drinks was imported (for LTL 751 million, 9.3%, by 1.3 times), as well as of meat (for LTL 704 million, 8.7%, almost by 1.5 times), of vegetables (for LTL 673 million, 8.3%, by 1.9 times), of fish and crustaceans (for LTL 575 million, 7.1%, by 15%). Apples accounted for 28% of fruit and nut import (189 thousand tons, by 3% more than in 2007, with the value increase of 33%). 80% of apples were imported from Poland. Plenty of citrus fruit was imported (68 thousand tons for LTL 178 million), as well as apricots, cherries and peaches (41 thousand tons for LTL 152 million), grapes (30 thousand tons for LTL 133 million), and other sorts of berries (19 thousand tons for LTL 113 million). Import value of the above fruit and berries accounted for 76% of the total fruit import. It should be noted that a large part of imported apples into Lithuania were later exported. 76% of fruit and nut production was imported from Poland, the Netherlands, Italy, Spain, Germany and Belgium.

Import of soft and strong drinks, including vinegar, ranks second by the scope of import. Most of vintage wine was imported (for LTL 197 million), alcohol, liqueurs and other strong drinks (for LTL 182 million), mineral and soda water (for LTL 179 million). The value of the above beverages accounted for 75% of the total import of beverages. Most of beverages were imported from Poland, the Netherlands, Italy, Spain, Germany, and Belgium. Import value from the said countries accounted for 76% of the total import of beverages into Lithuania.

The third largest group of import is meat import: of pork – 73,2 thousand tons for LTL 466 million (by 1.4 times more than in 2007); of poultry meat – 31,5 thousand tons for LTL 132 million; and of the variety meat – 7,0 thousand tons for LTL 30 million (by 14% more). Most of pork was imported from Poland (31%), Germany (28%), Estonia, Belgium, and Denmark. 86% of the total import of pork was from the above countries. 77% of poultry meat was imported from Poland, the Netherlands and Denmark (38%, 23% and 16% correspondingly). Most of the variety meat (79%) was imported from Germany, Poland, Estonia, Denmark, the Netherlands and Spain.

Plenty of vegetables were imported from Poland (41% for LTL 276 million), the Netherlands (33% for LTL 223 million), and Spain (9.2% for LTL 62 million). Most of fish and crustaceans were imported from Germany, Sweden, Latvia, Kazakhstan, USA, Norway, and Iceland – 60% of the total import of such products.

Import of crude milk for processing started in 2005 and amounted to 39 thousand tons, in 2006 – 119 thousand tons, in 2007 – 144 thousand tons, and in 2008 – 194 thousand tons. Import of milk in 2008, as compared with 2007, increased by 1.3 times, with the value increase of 1.4 times, amounting to LTL 206 million. 90% of crude milk in 2008 was imported from Latvia, 8.5% – from Estonia, and 1.5% – from Poland.

Analysis of export in 2008 of agricultural and food products into three groups of countries (the EU-15 – the old EU member states, the EU-12 – the new EU member states, and third countries – countries outside the EU) revealed that in comparison to 2007, export into the EU-15 decreased by 9.0%, and into the EU-12 increased by 21%. In total, export into the EU-27 increased by 5.5%, and the value of export amounted to LTL 5 089 million (Fig. 2.6). The share of export into the EU member states accounted for 57%, and in comparison to 2007 decreased by 9.6 per cent points. Export value into third countries increased by 56%, and the share in the total export of agricultural and food products increased from 33% to 43%. It should be noted that export into third countries was encouraged by export subsidies. Export return payments in 2008 amounted to LTL 28,5 million, including 83% (LTL 23,7 million) for export of cattle meat.

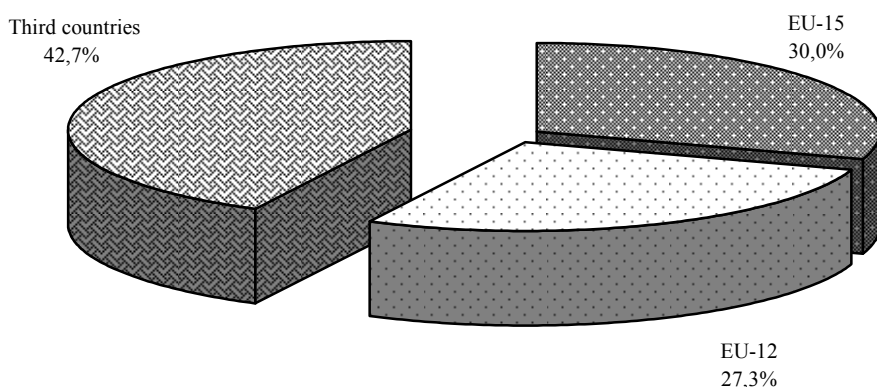

Fig. 2.6. Export structure of agricultural and food products by country group in 2008

Source: Department of Statistics to the GovRL

Export into the EU-27 consisted mostly of milk and dairy products (for LTL 753 million), grain (for LTL 460 million), products used for animal feed (for LTL 437 million), prepared and canned meat and fish articles (for LTL 418 million), and cigarettes (for LTL 372 million).

Most of export into third countries consisted of fruit and berries (for LTL 771 million), cereals (for LTL 657 million), milk and dairy products (for LTL 520 million), and vegetables (for LTL 505 million). Export value of the above products accounted for 65% of the total value of exported products into third countries.

The share of import from the old EU member states (EU-15) accounted for 43% of the total import of agricultural and food products (Fig. 2.7), and increased in comparison to 2007 by 3.1 per cent points, with the value increase of 1.4 times, amounting to LTL 3 457 million. Import from the EU-12 member states decreased by 3.0 per cent points, accounting for 40% and amounting to LTL 3 233 million. In total, the value of import from the EU-27 increased by 33%, and the share of it in the total import of agricultural and food products increased by 0.2 per cent points, accounting for

82.5% of the total import. Though import from third countries increased by 1.3 times, the share of it in the total import decreased.

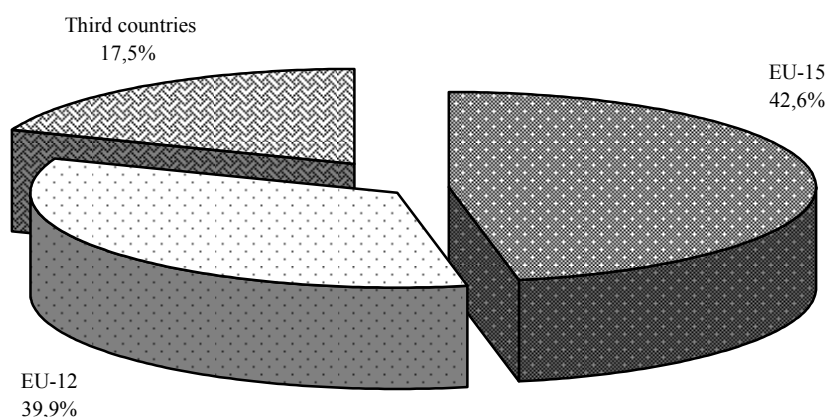

Fig. 2.7. Import structure of agricultural and food products by country group in 2008

Source: Department of Statistics to the GovRL

In 2008 the most important export partners (Fig. 2.8.) were Russia (29% of the total export of agricultural and food products), Latvia (14%), Germany (9.6%), Poland (6.1%), and Estonia (5.3%). Export into Russia increased almost by 1.5 times, into Latvia – by more than 1.2 times, into Poland – by 1.3 times, into Belarus – by 1.7 times, and into Belgium – by 2.1 times, but decreased into Germany (by 27%), the Netherlands (by 24%), and the United Kingdom (by 3.4%).

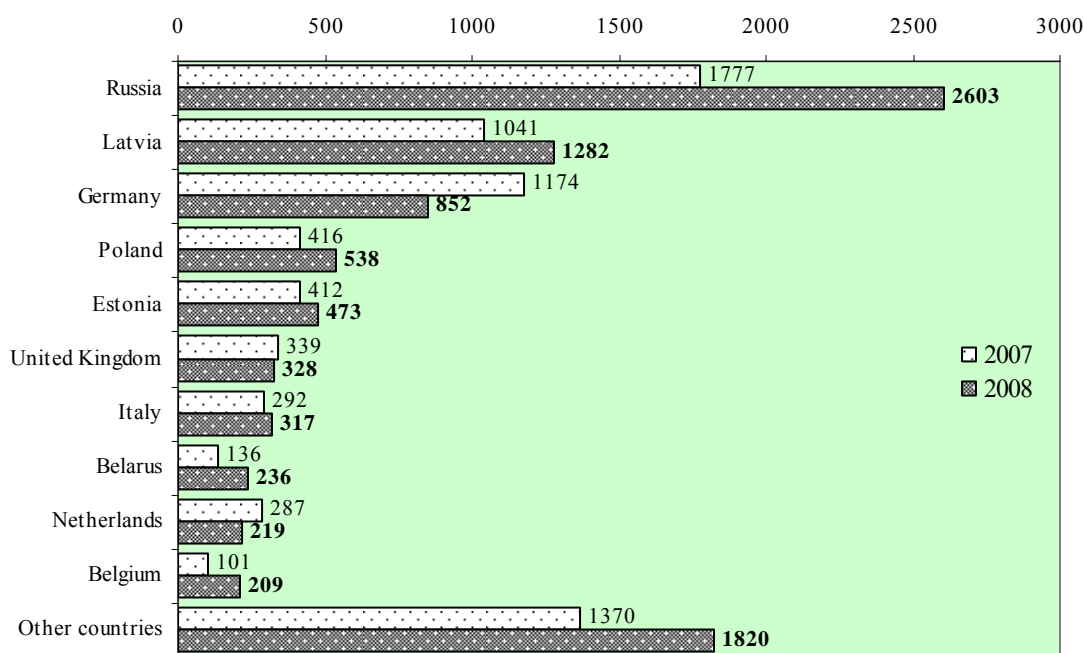

Fig. 2.8. Export of agricultural and food products by country in 2007 and 2008, in million Litass

Source: Department of Statistics to the GovRL

Most of agricultural and food products since 2006 is exported into Russia, where export of such products in 2008 amounted to LTL 2 603 million. Most of export into Russia consisted of cheese (for LTL 411 million, accounting for almost 16% of the total export of agricultural and food products into this country), apples (196 thousand tons for LTL 330 million, 13%), champignons, paprikas and other vegetables (in total for LTL 197 million, 7.6%), live pigs (353 thousand heads for LTL 149 million, 5.7%), and wine (for LTL 144 million, 5.5%). It should be noted that all amount of apples and wine exported into Russia, including 97% of vegetables, are of non-Lithuanian origin. The value of products of the Lithuanian origin accounted for 37% of the total export into Russia.

During the reference period export of agricultural and food products into Latvia increased by 23% in comparison to 2007. Most of the export consisted of cigarettes (for LTL 146 million, accounting for 12% of the total value of export of agricultural and food products into Latvia), cereals (212 thousand tons for LTL 121 million, 9.6%, exported by 6.8 times more than in 2007), sugar (26 thousand tons for LTL 58 million, 4.7%), and cheese and curd (for LTL 55 million, 4.4%, 1.5 times more).

Export into Germany, in comparison with 2007, decreased. 15% of the export consisted of cigarettes (for LTL 130 million, decreased by 2.2 times). 13% of the export value accounted for fish products and tinned fish (for LTL 46 million, by 1.5 times more). A substantial part of export consisted of cream (for LTL 88 thousand, by 40% less), fish fillet and other fish meat (for LTL 59 million, by 28% less), and feedstuffs for dogs and cats (for LTL 52 million, by 1.7 times less).

Export of 2008 into Russia, Germany and Latvia accounted for 53% of the total export of agricultural and food products (in 2007 – for 54%).

In 2008 most of products were imported from Poland, the Netherlands, Latvia, Germany, Estonia, the Ukraine, and Spain (Fig. 2.9). Import from these seven countries accounted for 66% of the total import of agricultural and food products.

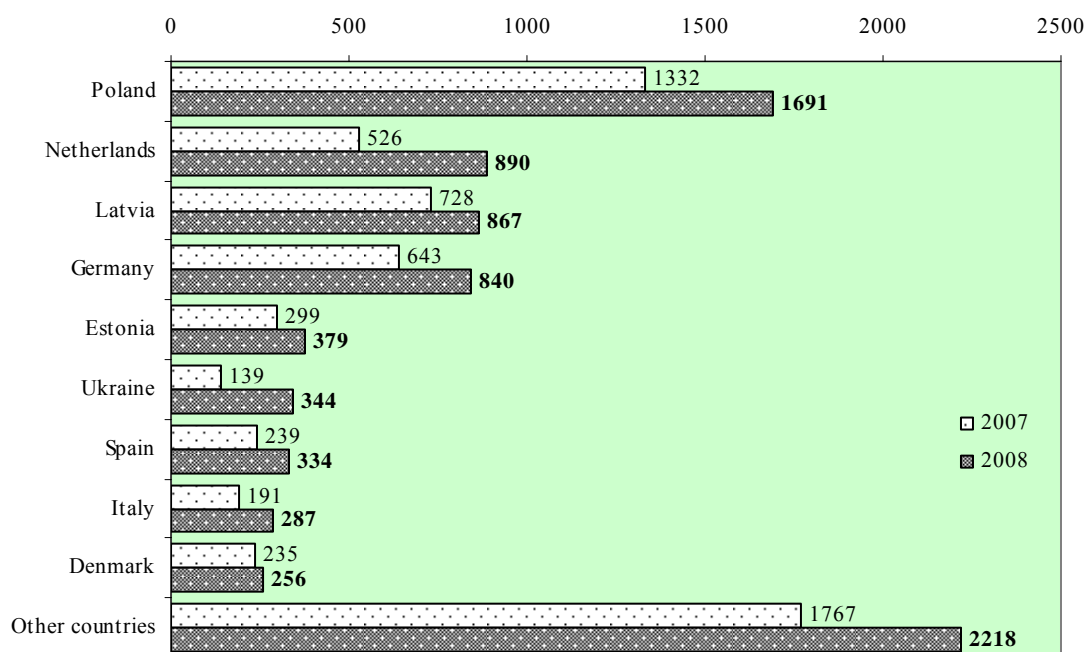

Fig. 2.9. Import of agricultural and food products by country in 2007 and 2008, in million Litass

Source: Department of Statistics to the GovRL

In the structure of import by countries Poland is in the leading position as from 2005. In 2008 import from Poland reached LTL 1 691 million (21% of the total import of agricultural and food products), and increased in comparison with 2007 by 1.3 times. Most of the import consisted of apples – 152 thousand tons for LTL 236 million, and accounted for 14% of the total import from Poland; of pork – 24,3 thousand tons for LTL 145 million, (8.6% correspondingly); of champignons, paprikas and lettuce plants – for LTL 94 million (5.5%); of tomatoes – 30,2 thousand tons for LTL 71 million (4.2%); and of various sorts of cabbage – 57,4 thousand tons for LTL 70,2 million (4.2%).

Import from the Netherlands amounted to LTL 890 million and accounted for 11% of the total import of agricultural and food products in comparison with 2007 – by 1.7 times more. Most of the import consisted of oilcakes and other cakes from hard soya bean oil extraction – for LTL 121 million (14% of the total import of agricultural and food products from the Netherlands). 11% of the import consisted of paprikas, eggplants, and lettuce plants (imported for LTL 93 million), 5.7% of citrus fruit (for LTL 51 million), 5.2% of apples and pears (for LTL 47 million) 4.7% of berries (for LTL 42 million), and 4.0% of tropical fruit (for LTL 36 million).

Import from Latvia amounted to LTL 867 million (10.7% of the total import of agricultural and food products in 2008). In comparison with 2007 import from this country increased by 1.2 times. 22% of import from Latvia consisted of crude milk (181 thousand tons for LTL 195 million). Import of cigarettes amounted to LTL 89 million (10.3% of the total import of agricultural and food products from Latvia), of strong drinks to LTL 44 million (5.1%), of bread, pies, cakes, and other sorts of pastry for LTL 38 million (4.4%), and of wheat for LTL 38 million (4.4%).

Import from Germany amounted to LTL 840 million – 10.4% of the total import of agricultural and food products into Lithuania. During the reference period import from Germany increased by 1.3 times. Most of the import consisted of pork (20,3 thousand tons for LTL 132 million, whereas in 2007 – 5,5 thousand tons for LTL 29 million); rapeseed oil (13 thousand tons for LTL 46 million); coffee (for LTL 46 million); various foodstuffs of CN group products, where a large proportion was baby food (for LTL 41 million), and fish (for LTL 40 million).

Balance of foreign trade in agricultural and food products was positive in 2008 and amounted to LTL 771 million, but decreased by 1.6 times in comparison with 2007. Balance of trade in live animals and products of animal origin decreased from LTL 922 million in 2007 to LTL 547 million in 2008. Positive balance of trade in vegetable products increased by 1.6 times as well as the deficit of trade in fats and oils. Balance of trade in prepared foodstuffs, beverages and tobacco products became negative (Fig. 2.10).

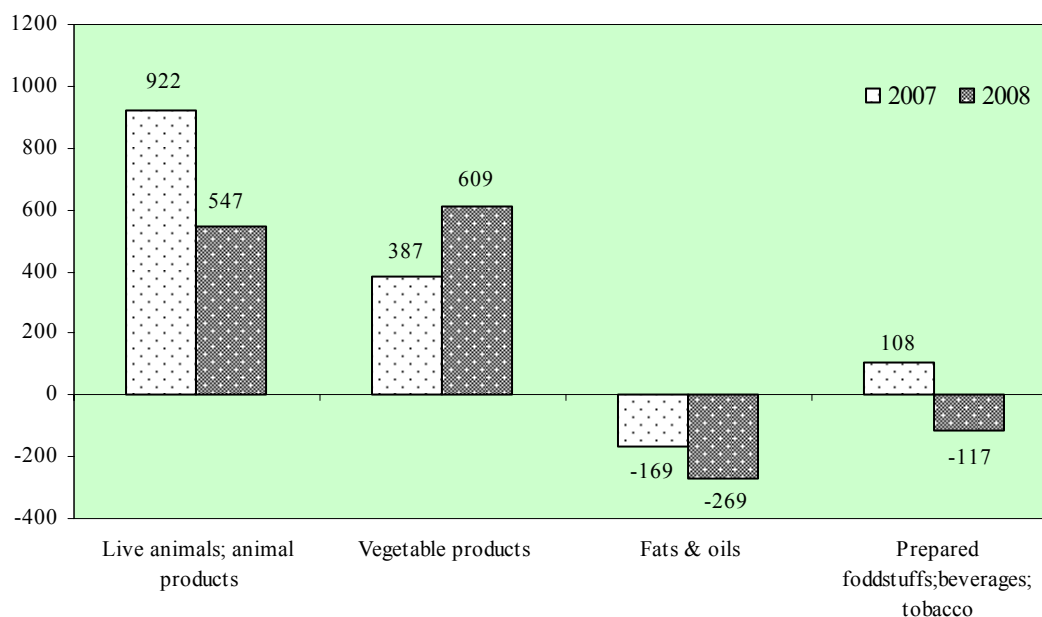

Fig. 2.10. Balance of foreign trade in agricultural and food products by product section in 2007 and 2008, in million Litass

Source: Department of Statistics to the GovRL

Highly positive trade balance was achieved in the sector of milk and dairy products, however, with the increasing import of crude milk and its share in the structure of import, it became by 17% lower than in 2007. Trade balance in grain was LTL 859 million. The highest negative trade balance was in the sector of soft and strong drinks, which amounted to LTL 360 million and increased by 1.3 times. Trade deficit in fats and oils, fish, meat and fruit was also high.

Analysis of the trade by countries (Fig. 2.11) revealed that surplus was achieved only in trading with third countries, which increased in comparison with 2007 almost by 1.8 times and amounted to LTL 2 371 million. Balances of trade with the EU-15 and the EU-12 member states were negative and have changed not for the benefit of Lithuania. The deficit of trade on the EU market (with the EU-27) increased even by 15 times and amounted to LTL 1 601 million (in 2007 it was LTL 103 million).

In 2008 foreign trade turnover by groups of countries indicate that it was similar as with the third countries as with the old EU member states (EU-15), correspondingly LTL 6 159 million and LTL 6 120 million. Turnover of trade with the EU-12 member states amounted to LTL 5 659 million. In total, the turnover of trade with the EU-27 member states increased almost by 1.2 times, and with third countries – by more than 1.6 times. The largest share – 66% – fall for the EU-27 member states, which in 2007 accounted for the larger part of 72%.

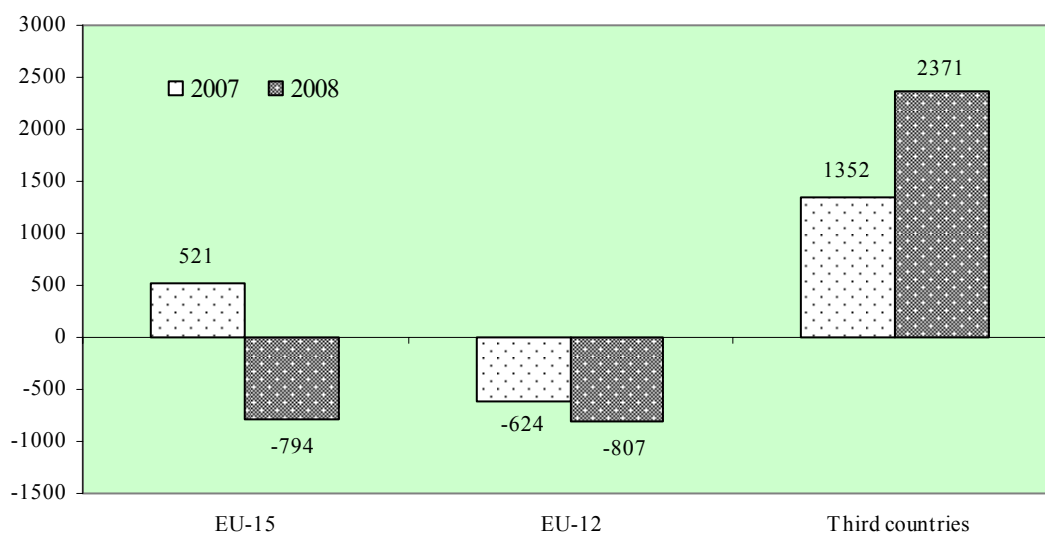

Fig. 2.11. Balance of foreign trade in agricultural and food products by country group in 2007 and 2008, in million Litass

Source: Department of Statistics to the GovRL

Major partners in foreign trade of agricultural and food products in 2008 were Russia (turnover of LTL 2 790 million, 16% of the total turnover of trading in agricultural and food products, increased by 1.4 times); Poland (LTL 2 229 million, 13%, 1.3 times); Latvia (LTL 2 149 million, 13%, 1.2 times), Germany (LTL 1 692 million, 10%, decreased by 7.3%); and the Netherlands (LTL 1 109 million, 5.5%, increased by 1.4 times). The highest positive balance was reached in the trade with Russia (LTL 2 417 million), Latvia (LTL 415 million), and the United Kingdom (LTL 239 million); the highest deficit – in the trade with Poland (LTL 1 154 million), the Netherlands (LTL 670 million), and the Ukraine (LTL 302 million).

By the end of 2008 economy in all countries found itself on a turning point, however, financial crisis will affect less foreign trade in agricultural and food products (first necessity commodities) than the trade in other kinds of goods.

3. Competitiveness of agricultural and food products in the domestic and foreign markets

3.1. Cereals

Lithuania enjoys rather favourable conditions for developing grain crops with prevailing average yielding soils, which by natural yielding capacity are close to the soils of some other countries in the region (Poland, Denmark, South Scandinavian countries, etc.). Though conditions in Lithuania by the duration of vegetation and the average temperature are worse, natural conditions provide a relative advantage in comparison with the neighbouring countries located further North. Lack of grain in 2006–2007 on the global and the EU grain markets encouraged Lithuanian farmers to

increase grain production. In 2008 grain crop area covered 60.6% of the total crop area (in 2007 – 58.1%, in 2006 – 55.7%). The area under grain crops in Lithuania is increasing, but the area under feeding and industrial crops is decreasing (Fig. 2.12).

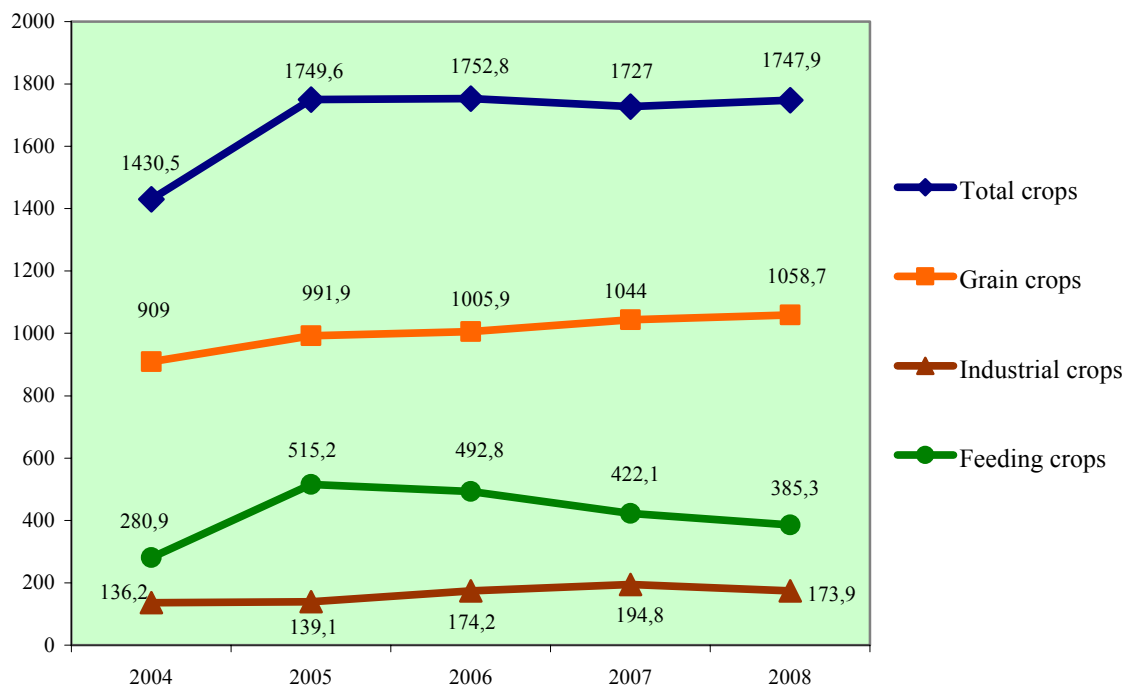

Fig. 2.12. Structure of crop area in Lithuania in 2004–2008, in thousand hectares

Source: Department of Statistics to the GovRL

Production. During the period of previous five years the area under grain crops and the structure thereof was changing with regards to the demand on the global, the EU and Lithuanian markets, purchase prices, foreign trade conditions, and direct payments.

The period of 2005–2007 was rather unfavourable for grain producers of most countries. Since 2005 the global consumption of grain was exceeding the production by almost 2.0% every year, leading to the reduction of grain stocks in the world by 11.6%, and in the EU-27 member states – even by 30.9%.

All importing countries were trying to restock grain resources, subsequently, the global demand in grain increased to almost 220 million tons per year, and the key grain exporters, including Russia, the Ukraine, and Kazakhstan, could only supply for the market only about 170 million tons annually. The increased demand in grain and the limited supply determined the rise in prices on grain. Boosting of grain prices on global markets influenced the prices on grain in Lithuania, too, encouraging at the same time national grain producers to develop this branch of crop production.

Since 2004 crop areas under grain started increasing in Lithuania (Fig. 2.13), and in 2008, as compared to 2004, increased by 16.5%.

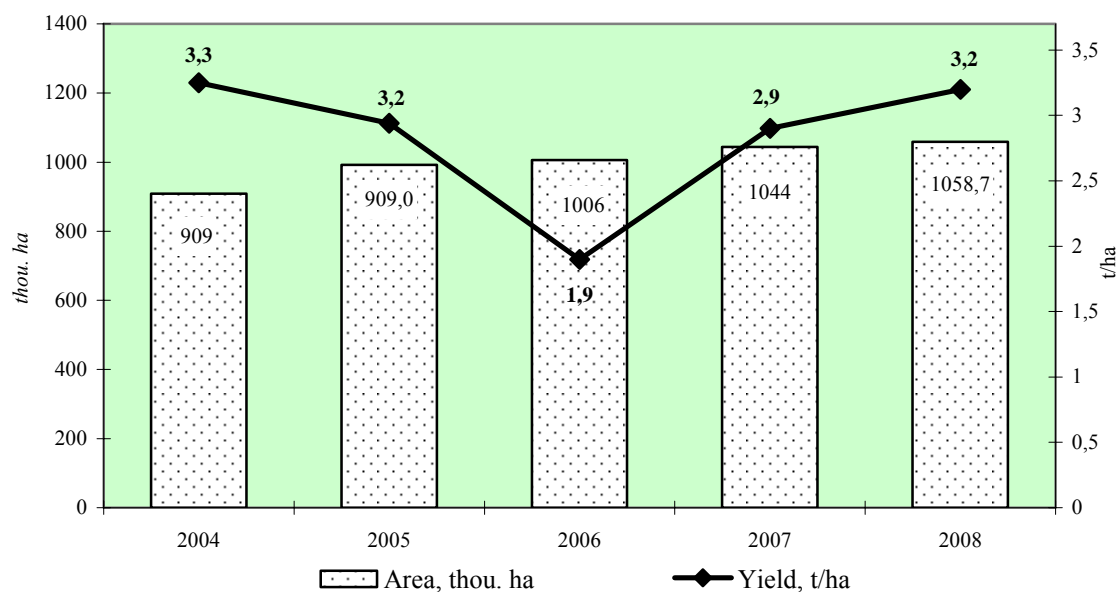

Fig. 2.13. Crop area and yield of grain crops in 2004–2008

Sources: *Statistical Yearbook of Lithuania, 2007.* – V.: Department of Statistics to the GovRL, 2008;
Agriculture in Lithuania 2007. – V.: Department of Statistics to the GovRL, 2008;
Crops 2008. – V.: Department of Statistics to the GovRL, 2008.

Largest areas of grain crops in 2008 were under wheat and barley (Fig. 2.14). Rather favourable climatic conditions in 2008 let agricultural crops to survive winter normally, grow and ripen. Subsequently, crop area under winter grain in 2008, in comparison to 2007, was by 12.5% larger (53,3 thousand ha): under winter triticale – by 34.1%, under winter wheat – by 8.4%, under winter barley – by 8.3%, and under rye – by 8.9%. In total, crop area under winter grain in Lithuania in 2008 amounted to 479,2 thousand ha: 299,8 thousand ha under winter wheat, 90,4 thousand ha under winter triticale, 76,0 thousand ha under rye, and 13,0 thousand ha under winter barley.

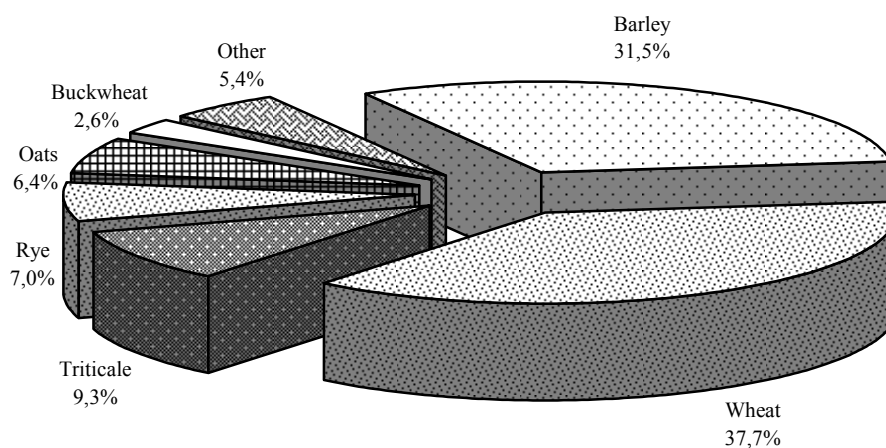

Fig. 2.14. Structure of cereal crop area in 2008

Source: Department of Statistics to the GovRL, 2008.

Spring grain in 2008 accounted for 52.7% of the total crop area under grain. Major part of the crop area was under barley – 332,5 thousand ha in 2008. Spring wheat covered the area of 113,5 thousand ha. In 2008 the area of 68,0 thousand ha was under oats, 10,1 thousand ha under mixed cereals, 36,7 thousand ha under pulse crops, 27,5 thousand ha under buckwheat, and 7,6 thousand ha under maize for grain.

In 2008 as much as 80.8% of all grain crops were cultivated in farmers' farms (855,4 thousand ha), and the remaining part – at agricultural partnerships and enterprises (203,3 thousand ha). In comparison to 2007, the area under grain crops at farmers' farms increased by 5.8%, and at agricultural partnerships and enterprises – by 11.4%.

Favourable climatic conditions contributed as to the survival of grain through the winter, as at the time of harvest. Accordingly, crop yield of grain in 2008 as compared to 2007 was much better (Table 2.5), amounting to a higher total yield of grain. According to the data of the Department of Statistics to the GovRL, grain yield of Lithuania in 2008, as compared to 2007, increased by 13.4%, and in comparison with the favourable year for grain crops of 2005 – by 21.4%.

Table 2.5. Average yield of grain crops in 2004–2008, in tons per hectare

Kind of grain crops	2004	2005	2006	2007	2008
Grain crops	3,21	2,89	1,88	2,94	3,29
cereals	3,25	2,94	1,99	3,01	3,35
winter cereals	3,76	3,46	2,25	3,65	4,14
wheat	4,12	3,85	2,42	4,16	4,76
triticale	3,18	2,73	1,88	2,95	3,27
rye	2,54	2,12	1,81	2,37	2,76
barley	3,78	3,24	2,17	3,15	3,94
spring cereals	2,75	2,53	1,74	2,53	2,69
wheat	3,45	3,24	2,13	3,08	3,01
barley	2,93	2,70	2,06	2,64	2,88
triticale	2,72	2,33	1,47	2,17	2,34
oats	2,23	1,92	1,30	1,94	2,07
buckwheat	0,59	0,55	0,20	0,96	0,76
mixed cereals	2,08	1,83	1,10	1,92	1,91
grain maize	2,20	3,08	1,57	4,82	4,24
other cereals	0,91	1,44	1,24	1,13	0,76
dried pulses grain	1,18	1,64	0,81	1,39	1,43

Source: Department of Statistics to the GovRL, 2008.

Increase of grain yield in 2008, in comparison to 2007, was influenced by 1.4% larger crop areas and by 11.9% increased yielding capacity (in comparison to 2005, crop area increased by 6.7%, and the yielding capacity – by 13.8%).

Grain crop yield, as compared with 2007, increased by 13.4% due to enlarged crop areas (by 1.9%), and higher yielding capacity (11.3%). Winter grain crops were enlarged by 9.0%, and the yielding capacity increased by 13.4% (as compared with 2005, crop area increased by 10.2%, and the yielding capacity – by 19.7%). Spring grain crop area decreased by 3.5%, and the yielding capacity increased by 6.3% (as compared with 2005, crop area increased by 4.3%, and the yielding capacity – by 6.3%).

Crop area under pulses decreased by 9.6%, and the yielding capacity increased by 21.4% (in comparison with 2005 crop area increased by 2.5%, and the yielding capacity by 6.3%).

The highest yielding capacity of grain crops in Lithuania in 2007 was reached in the counties of Šiauliai – 3,6 t/ha, Marijampolė – 3,4 t/ha, Kaunas and Panevėžys – 3,1 t/ha.

The yield of grain crops in Lithuania in 2008, as compared with 2004, increased by 2.5%, and of cereals – by 3.1%. The highest increase in the yielding capacity was achieved in cultivating maize – by 92.7%, pulses – by 21.2%, winter wheat – by 15.5%, and rye – by 8.7%. In 2008 the yielding capacity of some grain crops even decreased in comparison to 2004: of spring triticale – by 14.0%, of spring wheat – by 12.7%, and oats – by 7.2%.

National producers of cereals applying new technologies in cultivating and harvesting cereals at large specialised farms are continuously increasing the efficiency of grain production, however, the main culture – soft wheat – is of much higher yielding capacity in some neighbouring countries of the EU-27 than in Lithuania (Table 2.6).

Table 2.6. Average yield of soft wheat in some EU-27 countries in 2004–2008, in tons per hectare

Country	2004	2005	2006	2007	2008
Lithuania	4,03	3,73	2,36	3,92	4,27
Latvia	2,94	3,60	2,78	3,60	4,54
Finland	3,48	3,73	3,56	3,70	3,81
Sweden	5,99	6,35	5,46	6,26	6,30
Denmark	7,24	7,23	7,00	6,58	7,44
Netherlands	8,92	8,64	8,46	7,07	9,68
Germany	8,18	7,47	7,21	6,97	8,66
Poland	4,11	3,95	3,24	3,91	4,36
Hungary	5,15	4,50	4,07	3,60	5,10
Czech Republic	5,53	5,06	4,48	4,86	5,78
Slovakia	3,63	4,28	3,82	4,00	4,97

Sources: ZMP; Eurostat data

In 2008 the harvest of grain amounted to 3 484,2 thousand tons, or by 410,8 thousand tons (13.4%) more than in 2007 (Table 2.7).

Table 2.7. Average harvest of grain crops in 2004–2008, in thou. tons

Kind of grain crops	2004	2005	2006	2007	2008
Grain crops	2916,9	2870,0	1892,7	3073,4	3484,2
cereals	2859,4	2811,1	1857,8	3017,0	3421,9
winter cereals	1663,0	1458,1	822,0	1553,3	1921,3
wheat	1263,4	1148,7	620,4	1151,2	1381,1
triticale	241,7	175,5	97,5	199,1	286,4
rye	140,6	108,3	90,0	165,2	204,9
barley	17,3	25,6	14,1	37,8	48,9
spring cereals	1196,4	1353,0	1035,8	1463,7	1500,6
wheat	166,8	230,7	189,4	239,5	341,4
barley	842,5	922,7	729,7	975,9	921,5
triticale	21,7	25,6	12,9	28,5	24,6
oats	117,7	114,1	62,8	119,5	140,8
buckwheat	13,0	15,7	8,9	20,9	20,9
mixed cereals	31,6	39,0	27,0	52,6	19,2
grain maize	3,0	4,9	4,7	26,0	32,0
other cereals	0,1	0,3	0,4	0,8	0,2
dried pulses grain	57,5	58,9	34,9	56,4	62,3

Source: Data of the Department of Statistics to the GovRL, 2008.

In 2008 Lithuanian farmers received by 15.5% higher harvest of winter grain, in comparison with 2004, by 25.4% of spring grain, and by 8.3% of pulses. The total increase of grain crop harvest was reached due to the enlarged grain crop areas by 16.5%, and the higher yielding capacity of major agricultural cultures.

Grain procurement in Lithuania. In 2008, as compared with 2007, grain procurement from producers increased by 43.4% (746,9 thousand tons) (Table 2.8). Purchase of class II food wheat (274,2 thousand tons), triticale (99,8 thousand tons) and food rye (45,4 thousand tons) has increased mostly. Only purchase of buckwheat decreased by half.

Table 2.8. Purchase of grain in 2005 and 2008

Grain	Amounts purchased, thou. t				2008 compared to 2007, %
	2005	2006	2007	2008	
Total	1565,7	1082,0	1722,2	2469,1	43,4
wheat	1089,2	608,6	988,9	1537,5	55,5
food wheat, class I	125,0	200,8	144,1	210,7	46,2
food wheat, class II	188,2	67,0	436,0	710,2	62,9
rye	43,95	53,51	94,4	101,5	7,5
food rye, class I	16,44	23,65	19,6	65,0	3,3 k.
barley	377,6	377,2	525,7	615,2	17,0
food barley	5,03	9,31	40,1	42,7	6,5
malt barley	82,4	35,5	61,0	78,2	28,2

Grain	Amounts purchased, thou. t				2008 compared to 2007, %
	2005	2006	2007	2008	
oats	6,04	5,03	13,9	18,3	31,7
buckwheat	3,13	3,63	7,8	3,4	-56,4
triticale	44,72	33,35	84,5	184,3	118,1
maize	0,75	0,61	7,1	8,8	23,9

Source: AFMIS - Agriculture and Food Market Information System

In 2008, as during several previous years, the largest proportion of purchased grain crops consisted of wheat – 62.3%, and barley – 24.9%, rye – only 4.1%, and triticale – 7.5%.

Producers of cereals harvested in 2008 almost 410,8 thousand tons of grain more than in 2007, resulting in the increased grain supply. The increased grain supply on the Lithuanian market created realistic preconditions for replenishing grain stocks by more than 4% through the increased purchase, aiming at preventing hindrances for developing grain processing or increasing export in the case of favourable economic conditions.

Dropping prices on grain in the global and the EU markets influenced the decreasing level of prices on grain in the Lithuanian market as well. Subsequently, in 2008 grain crops in Lithuania were purchased at 10.3% lower price than in 2007 (Table 2.9). The average purchase price of food wheat in December 2008 was by 37.4% lower than in December 2007 (of feeding wheat – by 36.9%, of food rye – by 43.4%, of feeding barely – by 34.8%) (Fig 2.15–2.18).

Table 2.9. Average purchase price of grain in 2005–2008

Grain	Average purchase price, Lt/t				2008 compared to 2007, %
	2005	2006	2007	2008	
Total	301	382	631	566	-10,3
wheat	296	403	642	589	-8,3
food wheat, class I	350	460	657	675	2,7
food wheat, class II	324	412	691	622	-10,0
rye	263	349	530	508	-4,2
food rye, class I	304	388	577	496	-14,0
barley	324	354	643	543	-15,5
food barley	297	349	643	519	-19,3
malt barley	409	430	809	765	-5,4
oats	227	294	501	430	-14,2
buckwheat	625	824	901	656	-27,2
triticale	272	332	538	420	-21,9
maize	426	492	749	708	-5,5

Source: AFMIS - Agriculture and Food Market Information System

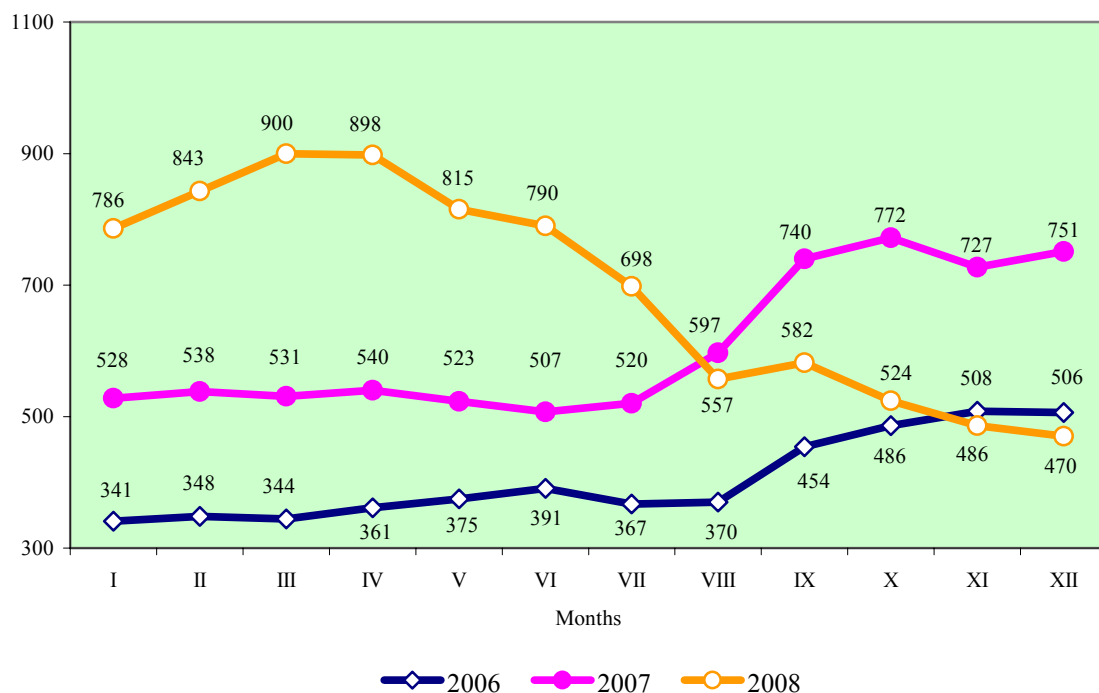

Fig. 2.15. Food wheat purchase prices in 2006–2008, in Litass per ton

Source: Data of the Department of Statistics to the GovRL, 2008. AFMIS - Agriculture and Food Market Information System

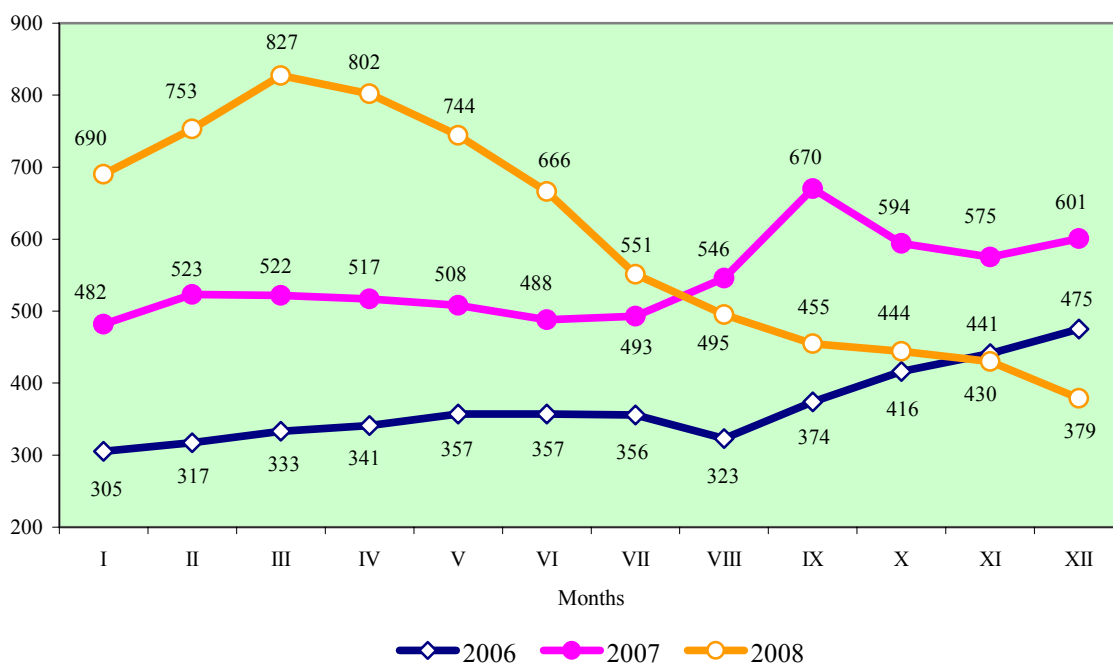

Fig. 2.16. Feed wheat purchase prices in 2006–2008, in Litass per ton

Source: Data of the Department of Statistics to the GovRL, 2008. AFMIS - Agriculture and Food Market Information System

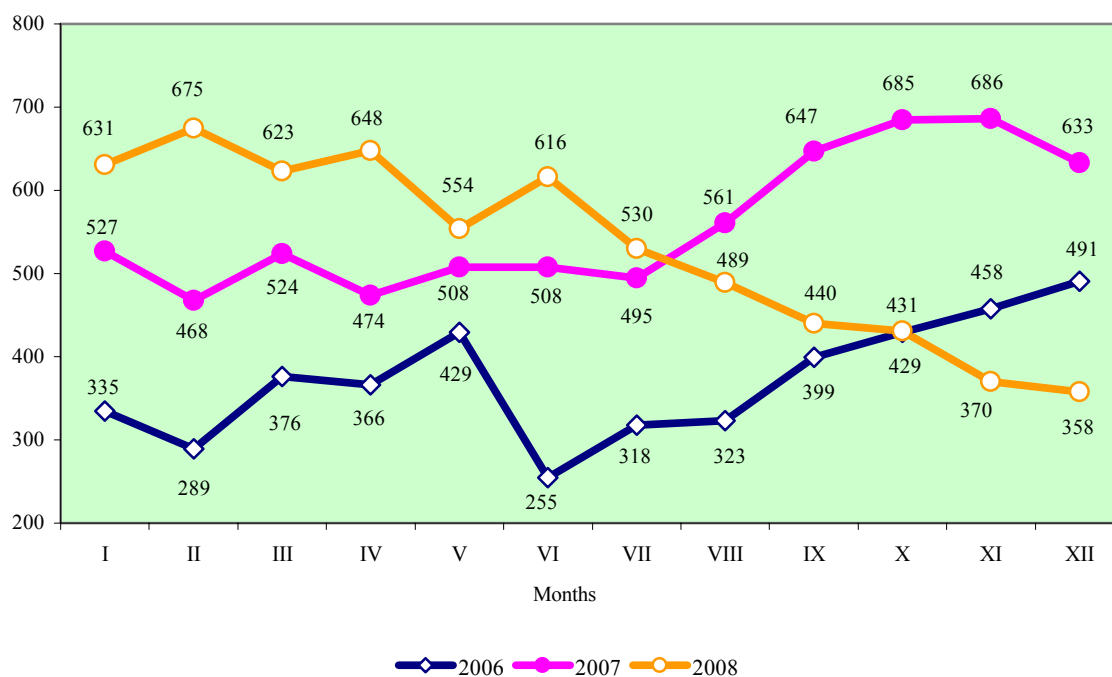

Fig. 2.17. Food rye purchase prices in 2006–2008, in Litass per ton

Source: Data of the Department of Statistics to the GovRL, 2008. AFMIS - Agriculture and Food Market Information System

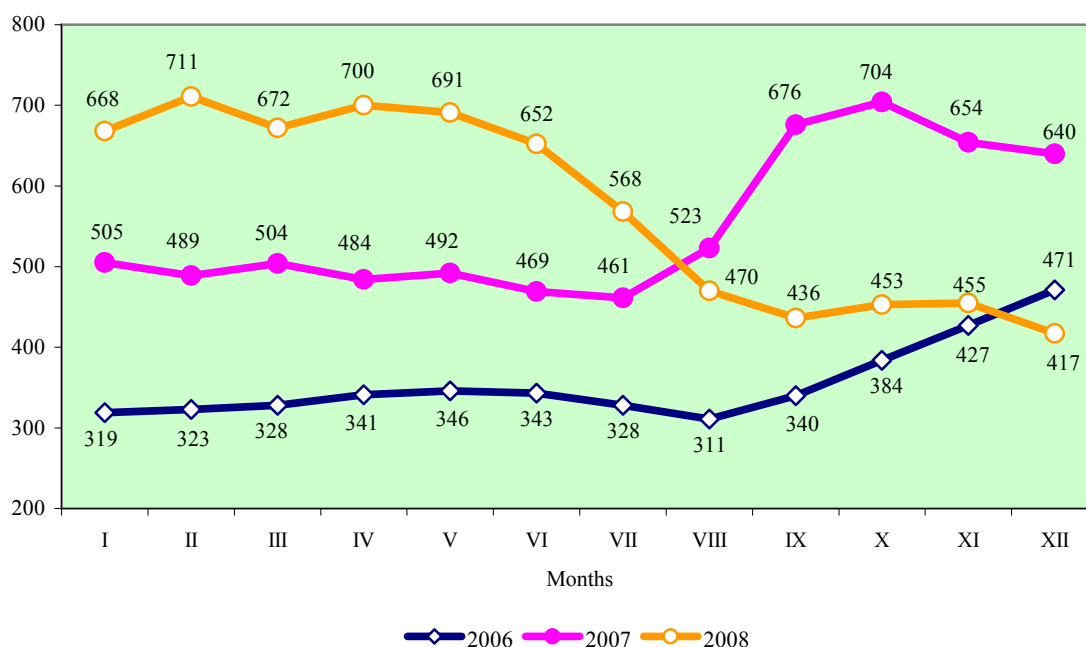

Fig. 2.18. Feed barley purchase prices in 2006–2008, in Litass per ton

Source: Data of the Department of Statistics to the GovRL, 2008. AFMIS - Agriculture and Food Market Information System

Processing. Within the year of 2008 Lithuanian processing companies processed 938, 83 thousand tons of grain, or almost 54 thousand (by 6.1%) more than during the year of 2007 (Table 2.10).

Table 2.10. Grain processing in 2007 and 2008, in thousand tons

Grains	Amount processed, thou t		2008 compared to 2007, %
	2007	2008	
Wheat	506,49	471,97	93,2
food wheat, class I	125,99	57,47	45,6
food wheat, class II	141,62	200,24	141,4
feed wheat	238,87	214,26	89,7
Rye	52,50	47,97	91,4
food rye	20,87	18,93	90,7
feed rye	31,63	29,04	91,8
Barley	227,99	236,33	103,7
food barley	0,84	0,11	13,1
malt barley	105,00	111,46	106,2
feed barley	122,15	124,76	102,1
Oats	4,01	10,42	2,6 k.
Buckwheat	5,46	9,32	170,7
Triticale	31,24	54,04	173,0
Maize	53,26	102,65	192,7
Peas	4,40	6,13	139,3
Total	885,35	938,83	106,1

Source: AFMIS - Agriculture and Food Market Information System

During the mentioned period the processing of oats, maize, triticale, and buckwheat increased, and of I class food wheat and rye decreased. Such changes were influenced by the modifications in the production and consumption. Moreover, processing changes by the assortment were influenced by a worse quality of grain. For example, total processing of wheat during the year of 2008 in comparison with 2007 decreased by 6.8%, and of I class food wheat – even by 54.4%, but of II class food wheat – increased even by 41.4%.

Grain stocks by the end of 2008 amounted to 388,9 thousand tons of wheat, 149.,1 thousand tons of barley, 87,6 thousand tons of triticale, 59,9 thousand tons of rye, 17,0 thousand tons of oats, and 3,6 thousand tons of buckwheat. In comparison with December 2007, grain stocks in main sorts of grain decreased by 3.6% of barley, 3.7% of wheat, and 9.5% of rye, but increased by 34.9% of oats, 2.3 times of triticale, and 52.2% of maize.

Production of cereal groats increased mostly during the recent years (by 17.0%) (Table 1.11). Though the total production of flour decreased only by 1.2%, but the production of rye flour decreased even by 24.6% because of the reduced production of bread products and confectionery (by 2.8% and 16.3% correspondingly).

Table 2.11. Production of grain products in 2004 and 2008, in thousand tons

Product group	2004	2005	2006	2007	2008
Flour	230,0	220,2	245,0	252,3	249,3
Cereal groats	19,4	32,3	21,1	20,1	23,4
Fresh bread:	152,0	158,7	152,5	141,4	142,0
rye bread	75,2	72,1	68,5	62,7	60,9
other bread	76,8	86,6	84,0	78,7	81,1
Pastry and confectionery	22,8	31,9	32,0	32,2	26,9

Source: Data of the Department of Statistics to the GovRL.

The decreased production volume of grain products had a direct impact on the trade thereof (Table 2.12). Only in 2008, as compared with 2007, sales of rye flour decreased mostly – by 31.3%, and of confectionery by 17.2%. Fewer amounts of rye bread (3.5%) and wheat flour (by 13.5%) were sold. Though in 2008 sales of the above products decreased approximately by 30 thousand tons, producers received LTL 106,8 million more income due to the increased sale-prices (Table 2.13).

Table 2.12. Sales of grain products in 2004 and 2008

Products	Amount sold, thou. t					2008 compared to 2007, %
	2004	2005	2006	2007	2008	
Wheat flour	146,75	145,26	148,49	136,15	117,73	86,5
Rye flour	44,78	39,17	43,65	23,91	16,42	68,7
Cereal groats:	13,07	23,72	17,62	13,77	16,10	116,9
wheat	3,93	10,51	5,46	3,13	3,83	122,4
semolina	1,71	1,66	1,30	1,19	1,61	135,3
oat, maize, rice, rye, barley	9,14	13,21	12,15	10,64	12,27	115,3
buckwheat	1,32	2,81	3,64	3,38	4,54	134,3
Fresh bread:	148,93	152,30	142,74	133,10	132,40	99,5
rye bread	72,71	69,58	64,75	60,41	58,32	96,5
other	76,22	82,72	77,99	72,69	74,08	101,9
Confectionery	21,71	31,19	31,19	31,17	25,80	82,8

Source: Data of the Department of Statistics to the GovRL.

Table 2.13. Average sale prices of grain products, Lt/t

Products	Average sale-price, Lt/t					2008 compared to 2007, %
	2004	2005	2006	2007	2008	
Wheat flour	744	616	699	944	1162	123,1
Rye flour	510	499	663	860	1014	117,9
Cereal groats:	680	667	944	1301	1419	109,1
wheat	662	552	674	998	1114	111,6
semolina	858	781	862	1128	1170	103,7
oat, maize, rice, rye, barley	687	760	1065	1390	1515	109,0
buckwheat	1645	1735	2076	2396	2194	91,6
Fresh bread	1758	1798	2015	2463	3076	124,9
rye bread	1617	1637	1840	2304	2881	125,0
other	1892	1934	2160	2595	3230	124,5
Confectionery	3975	4976	5645	6697	8790	131,3

Source: Data of the Department of Statistics to the GovRL

Average wholesale prices on grain products during the same period were much more rapidly increasing, than the average grain purchase prices: the average sales-price on wheat flour increased almost by a quarter, but on wheat grain was by 8.3% lower, sales-price on rye flour increased by about 18%, but on rye grain was by 4.2% lower, average sales-prices on cereal groats (except on buckwheat) have also significantly increased, though prices on barley dropped almost by 16%.

The rise of wholesale prices on grain products influenced the increase of retail prices on bread products (Fig. 2.19 and 2.20). Retail price on rye bread in December 2008, as compared with December 2007, was higher by 20.7%; on white bread from the highest sort of wheat flour increased during the same period by 18.1%. Dynamics of retail prices on the above products indicate that the price on brown bread increased by 20.4% within the year of 2008, and on white bread – by 18.4%, while during the period of 2006 – 2008 correspondingly by 80.8% and 69.3%.

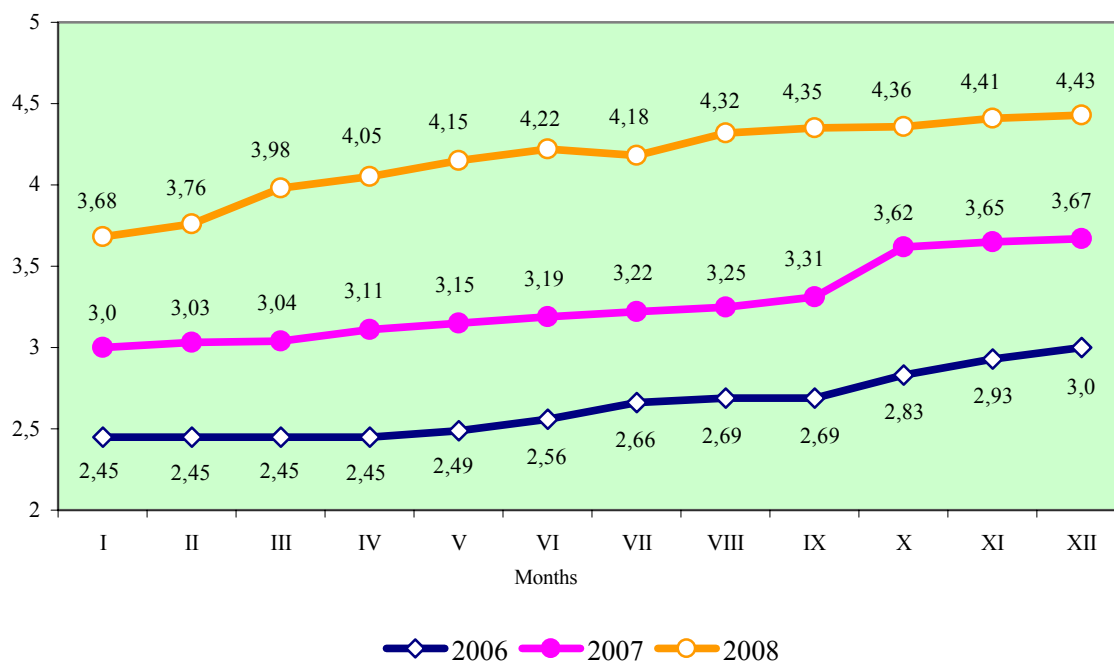

Fig. 2.19. Retail prices of rye bread in 2006–2008, in Litass per kg

Source: Data of the Department of Statistics to the GovRL,

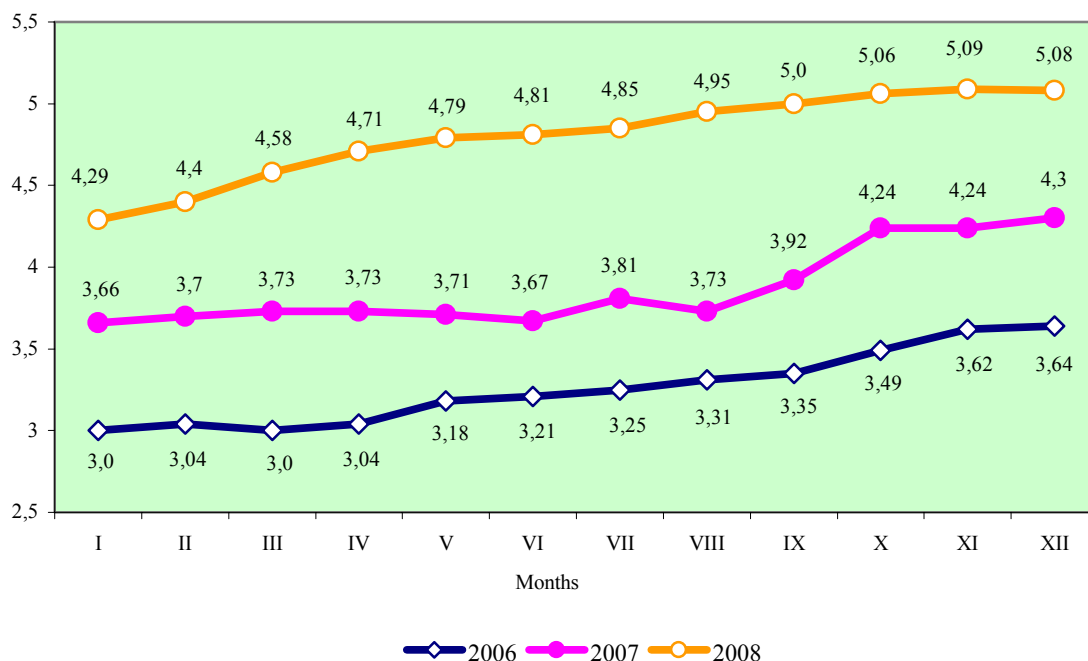

Fig. 2.20. Retail prices of a loaf of white bread made from the best-quality wheat flour in 2006–2008, in Litass per kg

Source: Data of the Department of Statistics to the GovRL,

Balance. Grain harvest in the period of 2004–2008 was sufficient to satisfy national needs (Table 2.14). Most of grain is consumed in livestock breeding. In 2004–2008 about 45.0% of grain produced on Lithuanian farms were used for feedstuffs.

The consumption of bread and grain in Lithuania is gradually decreasing. In 2008, as compared with 2004, per capita consumption was by 4.0% less, and the total population consumption fund decreased within the mentioned period by 5.0%. It is related to financial possibilities of consumers, diversity in the supply of food products, and changes in the assortment of consumption.

Table 2.14. Balances of grain and grain products in 2004–2008, in thousand tons

Indicators	2004	2005	2006	2007	2008*
Beginning stocks	1465,9	1507,6	1027,1	755,7	1083,7
Production	2916,9	2870,0	1892,7	3073,4	3484,2
Import	206,5	187,2	271,3	293,8	415,8
Total resources	4589,3	4564,8	3191,1	4122,9	4983,7
Export	582,8	1181,3	838,1	905,9	1832,4
Domestic uses	2498,9	2356,4	1596,7	2133,3	2107,1
seeds	257,7	215,8	219,9	228,1	229,3
animal fodder	1570,5	1503,7	823,2	1263,2	1244,8
losses	93,0	71,4	38,1	61,5	71,7
industrial uses	148,2	155,4	134,2	168,8	153,4
human consumption	429,5	410,1	381,3	411,7	407,9
Per capita consumption, kg	125	120	112	122	120
Ending stocks	1507,6	1027,1	755,7	1083,7	1044,2
Self-sufficiency level, %	117	122	118,5	144,1	165,4

* LIAE calculations.

Source: *Agriculture in Lithuania 2007, Vilnius: Department of Statistics to the GovRL, 2008.*

Foreign trade in grain and grain products. No doubt the situation on the markets of grain and grain products is significantly influenced by export and import. The export of cereal grains from Lithuania in 2008 exceeded the import more than 4.9 times (Tables 2.15 and 2.16). In comparison to 2007, the export of cereal grains increased 2.2 times, and the import increased 1.7 times. The export of milling products within the said period increased by 24.8%, and the import decreased by 16.5%.

Table 2.15. Export of grain and grain products in 2004–2008

Products	Amount exported, thou t					2008 compared to 2007, %
	2004	2005	2006	2007	2008	
Cereal grains	522,6	1089,1	764,1	722,5	1604,1	222,0
of which:						
wheat	367,7	781,0	406,7	438,5	1126,6	256,9
rye	8,2	13,6	10,3	24,1	60,1	249,4
barley	136,3	286,8	328,7	227,6	316,1	138,9
Milling products	41,4	59,5	58,3	113,7	141,9	124,8
of which:						
wheat flour	23,0	23,8	18,5	13,1	6,8	51,9
rye flour	1,13	0,79	0,56	1,3	1,1	84,6
cereal groats	5,3	5,7	3,7	2,9	3,1	106,9

Source: Foreign trade data base of the Ministry of Agriculture

Most of Lithuanian wheat during the previous year was sold for Latvia (18.8%), Algeria (18.0%), Morocco (13.8%), Oman (8.9%), and Turkey (8.3%). Most of rye was exported to Finland – 34.8%, Poland – 23.8%, and Germany – 18.7%, and barley – to Latvia – 15.2%, Poland – 13.4%, Syria – 10.7%, and Denmark – 10.0%. Most of wheat flour Lithuania sold to Russia – 44.5%, Latvia – 26.6%, and Estonia – 14.3%. Most of rye flour from Lithuania was bought by Poland – 49.8%, Latvia – 16.8%, and Israel – 13.6%. Cereal groats were mostly sold to Latvia – 49.4% and Estonia – 37.8%.

Most of wheat was imported from Ukraine – 59.7%, Latvia – 19.4%, Sweden – 5.4%, and Russia – 4.1%; rye – from Latvia – 68.1%, and Russia – 19.0%; barley – from Sweden – 47.1%, Latvia – 14.9%, Estonia – 11.9%, and Finland – 7.7%.

Lithuania purchased from Latvia 56.2% of wheat and 91.0% of rye flour, and from Estonia – correspondingly 28.9% and 7.0%. Import of cereal groats accounted for 41.2% from Poland, for 37.8% from Hungary, and for 13.7% from Latvia.

Table 2.16. Import of grain and grain products in 2004 and 2008, in thousand tons

Products	Amount imported, thou t					2008 compared to 2007, %
	2004	2005	2006	2007	2008	
Cereal grain	123,9	103,3	173,9	192,5	330,8	171,8
of which:						
wheat	37,7	14,2	82,5	44,6	115,4	258,7
rye	13,4	23,2	17,6	18,0	2,8	-6,4 k.
barley	6,1	23,9	15,4	57,4	37,6	-34,5
Milling products	53,0	48,8	49,6	50,3	42,0	83,5
of which:						
wheat flour	3,9	2,4	8,2	5,5	5,4	98,2
rye flour	-	3,4	1,7	16,6	17,2	103,6
cereal groats	1,4	2,0	1,6	1,8	1,5	83,3

Source: Foreign trade data base of the Ministry of Agriculture.

Grain export prices in 2008 were by 5.3% lower than in 2007 (Table 2.17). The highest export price was gained on wheat and wheat flour, and cereal groats. Import prices on wheat, rye and barley increased during the same period by 16.6%, 93.3% and 42.4% correspondingly. Most expensive of the imported grain products were wheat flour and cereal groats.

Table 2.17. Average prices of exported and imported cereal grain and grain products in 2007 and 2008, in Litass per ton

Products	Export price			Import price		
	2007	2008	change, %	2007	2008	change, %
Cereal grain	736	697	94,7	714	782	109,5
of which:						
wheat	682	726	106,5	586	683	116,6
rye	702	687	97,9	608	1175	193,3
barley	810	577	71,2	684	974	142,4
Wheat flour	820	1134	138,3	860	1160	134,9
Rye flour	849	1086	127,9	871	1011	116,1
Cereal groats	1047	1376	131,4	1067	1157	108,4

Source: Foreign trade data base of the Ministry of Agriculture.

World export prices on grain in December 2008 in comparison to December 2007 were correspondingly decreasing. The highest drop in prices was on the feeding wheat from the United Kingdom and on the feeding wheat and barley from France (Table 2.18).

Table 2.18. World grain export prices in 2007 and 2008, in Litass per ton*

Grain	Country, kind of grain	2007	2008		Change **, %	
		December	October	November		December
Wheat	USA, HRW, category 2	939	642	666	616	-34,4
	USA, SRW, category 2	889	504	518	494	-45,4
	Argentina	790	-	480	460	-41,8
	France, FCW 1	932	515	477	463	-50,3
	Germany, class B	932	548	534	474	-49,1
	UK, feed wheat	777	-	408	375	-51,7
	Canada, CWRS 13,5 b.	1173	844	882	855	-27,1
Maize	USA, 3 YC	488	478	430	435	-10,9
	Argentina	423	437	414	395	-6,6
Barley	France, feed barley	857	432	403	390	-54,5

* Prices (in Litass) according to the Lithuanian Bank exchange rate of the corresponding date.

** December 2008 compared to December 2007.

Note: HRW – Hard Red Winter; SRW – Soft Red Winter; FCW – French Channel Wheat; CWRS – Canada Western Red Spring; YC – Yellow Corn.

Source: Agricultural Market Agency data

Market regulation measures and support. After the accession to the EU similar grain market regulation measures are applied for Lithuania as for other EU member states: interventive purchase system, direct payments, and import and export regulation measures.

Through the implementation of the EU CAP, where the dissociation of support from production outputs is among the key goals of the programme, principles of the disbursement of direct payments for crops were changed as of 2007. The amount of support for applicants involved in farming and in the production of agricultural products from 2007 consisted of three parts: basic payments, disbursed from the EU budget, and additional national direct payments coupled and decoupled with production.

In 2008 the number of registered applications reached 182,84 thousand of applications for direct payments. The declared crop area eligible for the basic support was 2,62 million ha, and for the additional part of direct payments – 1,31 million ha. In 2008 the EU budget allocated for Lithuania the amount of LTL 637,74 million for direct payments, and the additional national payments from the state budget reached the amount of LTL 264,70 million.

The basic, or the so called one-time payment, paid for the declared UAA and crop areas meeting the set requirements, was LTL/ha 244,77 in 2008, irrespective of the kinds of cultivated crops. The total amount of direct payments for grain crop areas was calculated by adding up the basic payment from the EU budget with the additional decoupled (LTL/ha 13,00) and coupled (LTL/ha 131,00) with the production payments from the state budget.

The EU grain import is regulated by applying import duties and import licences, and export – by applying export refund payments, i. e. by covering the difference between the production and the global market price.

Economic indicators. Expenditure of agricultural partnerships on the production of one ton of grain from 2004 was increasing (Fig.2.21): in 2005 – by 3.7%, and within the year of 2006 even by 60.3%.

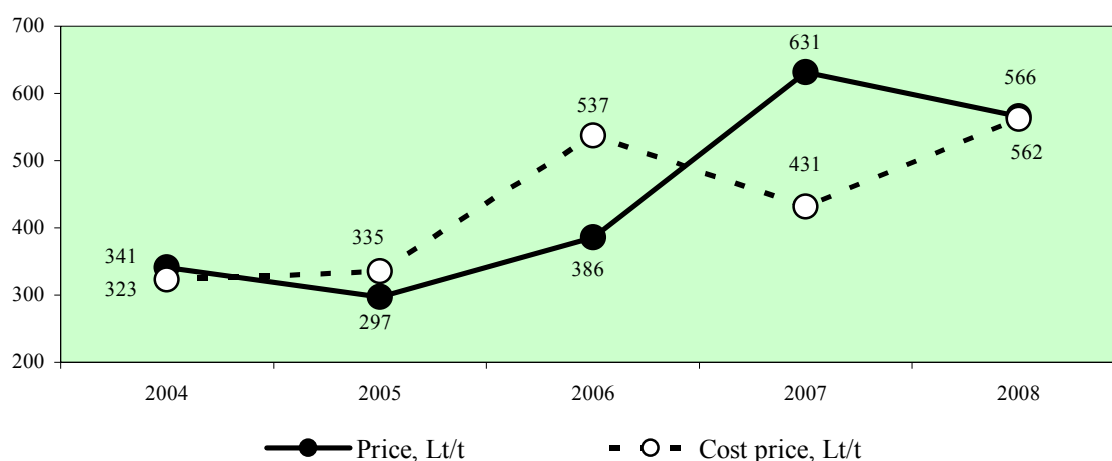

Fig. 2.21. Average grain sale price and cost price in agricultural companies in 2004–2008, in Lit per ton

Source: Department of Statistics to the GovRL;
Aggregated data of the Official statistical forms of agricultural companies and enterprises 2004–2008.

Such dramatic increase of expenditure per production unit was influenced by two major reasons: first, in 2006 expenditure increased by 4.9% as a result of the increasing prices on material and energetic resources, and the rise in wages (expenditure on fertilizers increased by 10.5%, for seeds – by 10.9%, for oil products and gas – by 5.8%, and for wages – by 12.1%); second, the decreased yielding capacity of grain crops and the total harvest of cereals.

In 2005–2006 income from the sales of grain, payments exclusive, did not cover the production costs neither of agricultural partnerships nor of farmers' farms. In 2007 due to the sales of grain at almost 63% higher price and a decreased cost price per one ton of grain (according to the LIAE calculations), the production of grain became very profitable again: payments exclusive by 70%, and payments inclusive – approx. by 140%. Such rapid increase of the profitability in grain production in 2007 was influenced by the increased purchase price (63%) on grain, and the enlarged yielding capacity of grain crops by 1.5 times, and the entire grain harvest. In 2008, in comparison with 2007, expenditure on the production of one ton of grain increased by 30.4% (according to the LIAE calculations). Such increase of expenditure was influenced by the increased price on fertilizers and soil improvement substances (31.7%), the increased wage (13.1%), and the increased price on oil and gas products (11.2%). Purchase prices on grain during the same period decreased by 10.3%, subsequently, the profitability of grain production in 2008 accounted only for some 0.7% (payments exclusive), and for 23.0% payments inclusive.

Two recent years were rather favourable for Lithuanian grain producers: the yielding capacity of grain crops was increasing amounting to the higher total grain yield. However, the increased grain supply in 2008 almost to 1.7 times (in 2007 – to 1.4 times) exceeded the demand in satisfying domestic needs. This was actually the main reason creating realistic economic preconditions for reducing purchase prices on grain and for worsening the profitability of the entire branch.

Subsequently, Lithuanian producers of grain, to our opinion, should apply more actively preliminary contractual obligations concluded between grain processing enterprises and grain trading organisations. This would facilitate to create preliminary contractual guarantees safeguarding the future grain outlet before starting its production.

3.2. Milk

Significant fluctuation of prices in the Lithuanian milk and dairy sector in 2007 – 2008 were influenced by the tendencies of global prices on milk and dairy products. In 2004–2006 prices on milk and dairy products were slowly increasing, but from the middle of 2007 they markedly jumped up (Fig. 2.22). In December 2007 in comparison with the same month of 2006, producer prices increased by 37%, including 23% on the domestic market, and 49% on export markets. Purchase price on milk jumped up by 53% during the same period. In 2008 prices on dairy products have notably decreased: by 15% on the average, by 22% on goods sold in foreign markets, and by 5.5% – on the Lithuanian market. However, the level of prices on dairy products remained higher than at the beginning of 2007. In December 2008, as compared with January 2007, they were higher by 16% on the average. The same cannot be said about the purchase price on milk, which decreased by 3.3% during the same period.

Fluctuation in the prices on milk and dairy products influenced the development of the entire milk sector.

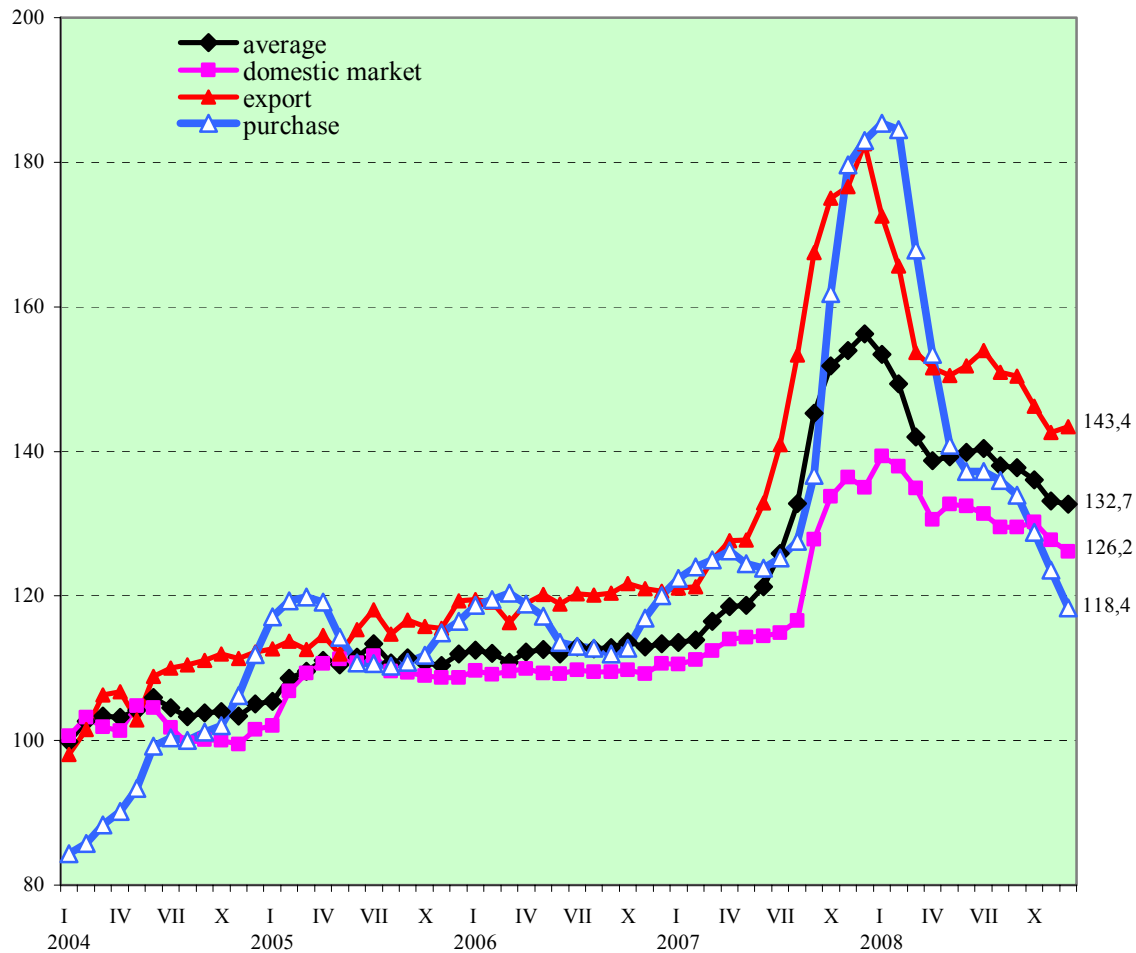

Fig. 2.22. Changes in producer prices of dairy products and milk purchase price in 2004–2008 (2003 December = 100%), in per cent

Sources: *Information about Rates of Changes in Producer Prices for Industrial Production. 2004–2008. V.: Department of Statistics to the GovRL;*
Purchase of agricultural products. 2004–2008. Vilnius: Department of Statistics to the GovRL.

Milk production and procurement. In 2008 milk yield amounted to 1 883,8 thousand tons, 88% of which was purchased for processing (Table 2.19). In comparison to 2007 milk production decreased by 2.7%, and the purchase increased by 2%. Such changes were influenced by the reduction of milk purchase prices, which started decreasing in February 2008, and the pessimistic future forecasts.

Major part of milk is purchased from farmers and family farms, however, the comparative level of agricultural partnerships and enterprises is slowly increasing. In 2004 they supplied 16.3% of the purchased milk calculated into the equivalent of basic fatness, and in 2007 – 19.3%.

Table 2.19. Milk production and procurement in 2004–2008, in thousand tons

Indicators	2004	2005	2006	2007	2008	2007 compared to 2004, %
Milk production	1848,7	1861,6	1891,3	1937,0	1883,8	102
Milk purchase:						
natural fatness	1140,0	1200,7	1296,1	1348,5	1376,1*	121
basic fatness**	1370,8	1432,8	1555,2	1628,2	1660,8	121

* 4,15% milk fat, 3,28% protein.

** 3,4% milk fat, 3,0% protein.

Sources: *Economic and social development in Lithuania. Dec 2008.* – V.: Department of Statistics to the GovRL, 2009; *Agriculture in Lithuania 2007.* – V.: Department of Statistics to the GovRL, 2008.

Import of crude milk in 2008 was much more rapidly increasing than milk procurement in Lithuania. During the year of 2008 import of crude milk amounted to 193,6 thousand tons, 90% of which was imported from Latvia, and accounted for 34% more than in 2007. The average price of the imported crude milk – LTL/t 1 064. Export of crude milk in 2008 amounted to 3,7 thousand tons. In comparison with 2007, the exported amount of crude milk was by 40% less, moreover, export was not performed on a continuous basis. The average price of the exported crude milk was LTL/t 873.

The quality of purchased milk is constantly increasing. In 2004, EU veterinary hygiene requirements were satisfied by 91% of the purchased milk, and in 2008 this percentage increased to 96%. Indicators of milk composition have not changed much. The average fatness of purchased milk in 2004–2007 was 4.1%, and increased in 2008 by 1 percentage point up to 4.2%. Protein content remained of 3.3% during the entire period.

Milk purchase prices were continuously increasing since 2004 with the opening of the single EU market. In 2008, as compared with 2004, the purchase price on milk of basic fatness increased by 46% (Fig. 2.23).

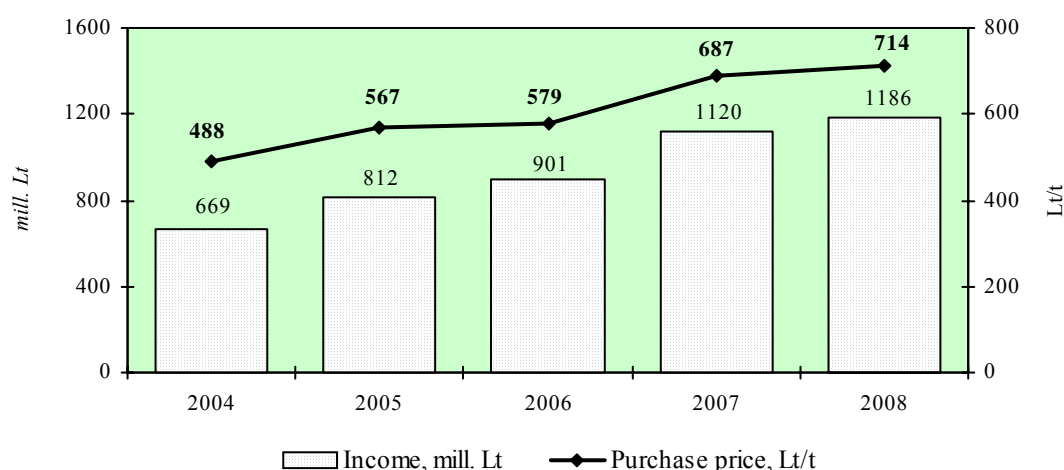
**Fig. 2.23. Milk (3.4% fatness) purchase price and income in 2004–2008**

Sources: *Agriculture in Lithuania 2007.* – V.: Department of Statistics to the GovRL, 2008.

Economic and social development in Lithuania. Dec 2008. – Vilnius: Department of Statistics to the GovRL, 2008; Ministry of Agriculture [interactive], [visited on 12 may 2009]. Access through Internet:

<http://www.zum.lt/lt/naujienos/pranesimai-spaudai/6738/>

In 2008 purchase price on milk decreased from LTL/t 923 in January to LTL/t 591 in December, or by 44% getting closer to the prices of the end of 2005 and the beginning of 2006. Such changes were influenced by the globally falling demand in dairy products and the reduced export prices. Nevertheless, the average purchase price in 2008 was by 3.8% higher than in 2007 due to the high level at the beginning of the year and traditionally remained the lowest in the EU (Fig. 2.24). Among major reasons for that are the dominating small scale milk producers, who are paid lower prices than the large scale producers.

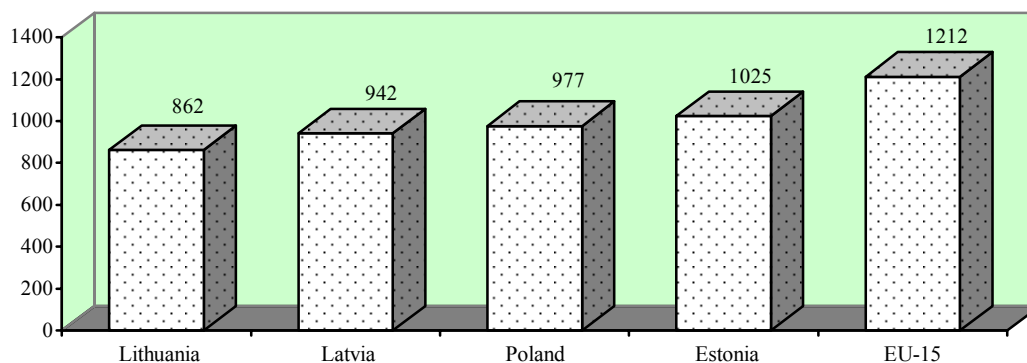

Fig. 2.24. Milk (natural fatness) purchase price in Lithuania and some EU countries in 2008, in Litass per ton

Sources: Purchase of agricultural products 2008 01 01. Vilnius: Department of Statistics to the GovRL 2008 Ministry of Agriculture [interactive], News [visited on 23 February 2009]. Access through Internet: <http://www.zum.lt/lt/naujienos/pranesimai-spaudai/6738/>;
 Eesti statistics [interactive], [visited on 23 February 2009]. Access through Internet: <http://pub.stat.ee/px-web.2001/temp/AG182007911535078.xls>;
 Główny Urząd Statystyczny [interactive], [visited on 23 February 2009]. Access through Internet: http://www.stat.gov.pl/gus/45_1335_ENG_HTML.htm;
 International Milk Price Reviews [interactive], [visited on 23 February 2009]. Access through Internet: <http://www.milkprices.nl/>;
 Latvijas statistics [interactive], [visited on 23 February 2009]. Access through Internet: <http://data.csb.gov.lv/temp/07-14a20079120515.xls>.

The average Lithuanian dairy farm is among the smallest in the EU-25 member states, where only 2,7 cows were kept in 2005 (18% of the EU average).

Since 2004 until the end of 2008 the number of farms keeping cows has substantially decreased – by 73 495. The largest reduction was noted among small farms keeping from 1 to 2 cows – 56 232. Reduction was also noted among farmers keeping from 3 to 9 cows, but the number of larger farms keeping cows has increased by 1 704. During the period of 2004–2008 the number of dairy farms keeping 10–19 cows has markedly increased - by 502 during the reference period. The average size of a dairy farm increased within the said period by 35%, up to 3,5 cows (Table 2.20). However, small dairy farms are yet prevailing. More than 10 cows are kept only by 5.4% of Lithuanian milk producers.

Due to the dominating position of small scale dairy farms in Lithuania the average productivity per cow is significantly lower than in the EU, accounting for 78% of the EU-27 average (data of 2007). However, the productivity during the reference period has been continuously increasing. In 2008 milk yield per cow amounted to 4 778 kg of milk, by 14% more in comparison to 2004 (Fig. 2.25). The average yield

per cow under control during the control period of 2007–2008 amounted to 5 900 kg., approximately 50% of all kept cows are under control.

Table 2.20. Dairy farms by number of cows in 2004 and 2008 (at the end of the year)

Number of cows per farm	2004		2008	
	number of farms	number of cows, thou.	number of farms	number of cows, thou.
1–2	138591	180,2	82359	101,6
3–9	38505	162,9	19536	89,3
10–19	2918	37,4	3420	45,2
20–29	589	13,8	1037	24,6
30–49	332	12,2	769	28,6
50–99	166	11,1	410	27,3
≥100	151	45,2	226	63,5
Total	181252	462,9	107757	380,2
Average		2,6		3,5

Source: Agricultural Information and Rural Business Centre [interactive], [visited on 18 May 2009.]. Access through Internet: http://www.vic.lt/failai/16.06_ukiu090101_pagal_gyvas_karvs11.pdf
http://www.vic.lt/failai/16.07_ukiu090101_pagal_gyvas_karvs21.pdf http://www.vic.lt/failai/16.08_ukiu090101_pgl_gy_kar22.pdf

The number of dairy cows decreased from 2004 to 2008 by 39,2 thousand heads (Fig. 2.25). The number of cows was continuously decreasing, except for the year of 2007, when rapidly increasing purchase prices encouraged farmers to increase the number of cows. In 2008, when prices dramatically dropped, the number of dairy cows decreased again, by 2.4% in comparison to 2007.

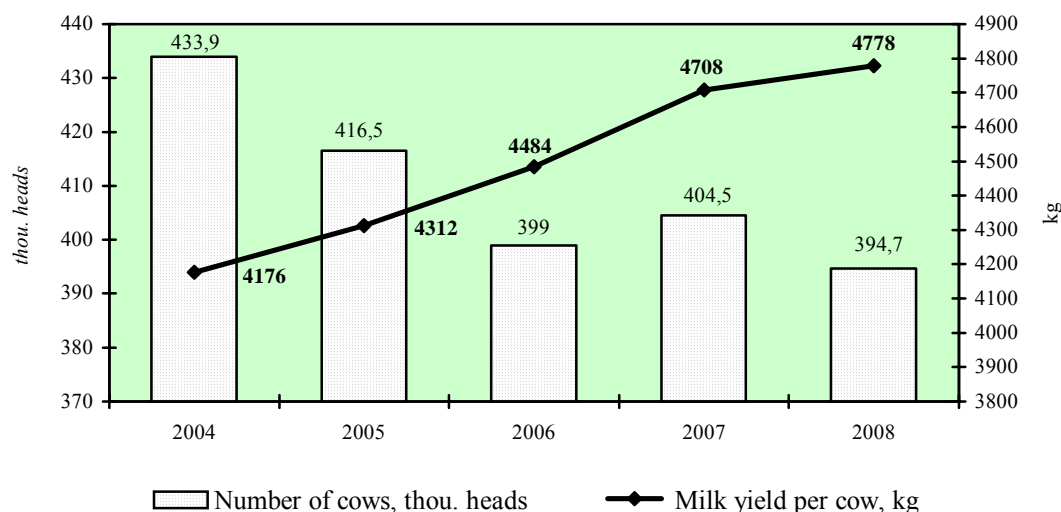

Fig. 2.25. Number of dairy cows and milk yield per cow in 2004–2008 (at the end of the year)

Sources: Agriculture in Lithuania 2007. Vilnius: Department of Statistics to the GovRL, 2008; Economic and social development in Lithuania, December 2008. – Vilnius: Department of Statistics to the GovRL, 2009; Department of Statistics to the GovRL [interactive], [visited on 18 May 2009.]. Access through Internet: <http://db1.stat.gov.lt/statbank/selectout/print.asp?pxfile=D:\statbank\Temp\20095181344401889041M5010401.px&outfile=D:\statbank\Temp\20095181344401889041M5010401&FileformatId=2&Queryfile=20095181344401889041M5010401&PLanguage=0&MainTable=M5010401&MainTablePretext=Gyvulių%20ir%20paukščių%20skaičius.%20Požymiai:%20rūšis&potsize=2&Buttons=5&TableStyle>

Manufacturing of dairy products. Dominating position in the Lithuanian sector of milk processing is taken by the three milk processing groups of companies: AB „Rokiškio sūris“, AB „Pieno žvaigždės“, and AB „Žemaitijos pienas“. These groups of companies raised in 2008 approx. 80% of the total income from the sales in the milk processing sector. The said groups of companies are also major exporters of dairy products. Other dairy companies and partnerships are much smaller, however, some of them are also exporting a considerable proportion of their output.

All Lithuanian dairy companies and their subsidiaries have implemented the EU requirements on sanitary hygiene in food production and are entitled to export their production to the EU member states. 16 dairy companies have acquired licences for exporting their production to Russia.

The greatest impact on the growth of production and trade in dairy products during the period of 2004–2008 was made by the accession of Lithuania to the EU in 2004, and the increasing global demand in dairy products and prices in 2007.

In 2004, the year of accession to the EU, sales in dairy products increased by 25%, and export – even by 41%; in 2007, as compared with 2006, – by 29% and 35% accordingly (Table 2.21). The notably decreasing global demand in dairy products conditioned the reduction of export by 4.3% in 2008, as compared to the previous year, leading to the decrease of sales in general by 1.7% .

Table 2.21. Key indicators of the milk processing industry in 2004–2008

Indicators	2004	2005	2006	2007	2008
Number of milk processing enterprises	37	37	35	34	33
Sales, mill. Lt	1486,3	1616,9	1806,1	2333,9	2294,8
share in total sales of the food industry, %	26,3	25,6	25,3	26,0	23,5
Exports, mill. Lt	797,6	888,6	1027,5	1388,7	1328,6
share in total export income, %	54	55	57	60	58

Sources: *Production of Commodities. 2003–2007.* – Vilnius: Department of Statistics to the GovRL; *Industrial Activity Results. Dec 2008.* – Vilnius: Department of Statistics to the GovRL, 2009; *MoA Foreign trade data base;* *National Food and Veterinary Service of the Republic of Lithuania [interactive], [visited 18 May 2009]. Access through Internet: <http://vetlt1.vet.lt/vepras/>*

The main course in the specialization of milk industry in Lithuania is the production of cheese. These products prevail in the structure of export, too. In 2008, as compared with 2004, manufacturing of all dairy products, except for butter, increased. Butter production indicator decreased because of the changes in the methodology of defining products to milk fats, introduced in 2006. Moreover, more and more milk fat is exported in the form of sweet cream. The production of fresh cheese (by 4 times) and milk preserves (3.1 times) has been developing most rapidly (Table 2.22).

Table 2.22. Production of main dairy products in 2004–2008, in thousand tons

Dairy products	2004	2005	2006	2007	2008	2008 compared to 2004, %
Drinking milk*	72,6	77,0	83,6	97,8	105,0	145
Cream	26,0*	37,5*	40,5	43,4	53,9	x
Kefir, sour milk	27,4	29,1	33,9	35,3	35,9	131
Yoghurt	15,2	14,6	18,1	17,3	15,3	101
Sour cream	26,8	27,2	25,1	26,6	27,9	104
Curd	12,1	13,4	17,7	21,5	23,3	193
Butter and other milk fats	15,6	16,1	11,8	12,3	9,0	58
Fresh cheese	7,6	7,7	20,8	22,6	30,7	404
Fat cheese	56,3	58,9	62,6	52,3	56,3	100
Dried milk and whey products	28,9	27,0	33,8	35,7	40,0	138
Ice cream*	20,7	19,0	22,8	24,3	25,1	121
Canned dairy products	9,6	11,7	14,8	22,0	29,8	310

* Mln. l / Million litres.

Sources: *Production of commodities. 2005–2007.* – Vilnius: Department of Statistics to the GovRL; *Economic and social development in Lithuania, December 2008.* – Vilnius: Department of Statistics to the GovRL, 2009; *Statistical Yearbook of Lithuania 2004.* – Vilnius: Department of Statistics to the GovRL, 2004.

Domestic market in dairy products. Consumption of milk and dairy products in milk equivalent per capita during the period of 2004–2007 in Lithuania decreased by 12%. Among the main reasons for the decreasing consumption of milk is lower consumption of milk produced in the farms for own needs. In general, the consumption of dairy products increased by 13% – 45% (Table 2.23), own-produced and consumed products and direct sales excluded.

The reduction in butter consumption was the result of the amended calculation methodology. In 2007 as compared with 2007 the notably increasing prices on dairy products did not influence the consumption much, because population income was increasing more rapidly than the prices on dairy products. The purchasing power of the population in 2007, as compared with 2006, and calculated in butter equivalent, increased by 13%, and in milk equivalent – by 12%.

Following the price jump on retail dairy products on the domestic market in the second half of 2007, when in December 2007, as compared with December 2006, price index of pasteurized milk increased by 28.5%, of canned milk – by 28.3%, of cheese and curd – by 30%, of butter – by 44%, and of other dairy products – by 29.1%, prices on some dairy products decreased in 2008: in December 2008 as compared with December 2006, the price on butter decreased by 13.7%, cheese and curd – by 6.7%. The price on pasteurized and canned milk was increasing further, correspondingly by 0.4% and 8.5%.

Table 2.23. Changes in the consumption of milk and dairy products and factors influencing the consumption in 2004–2007

Products	2004	2005	2006	2007	2007 compared to 2004, %
Per capita consumption of milk and dairy products, kg					
Milk and dairy products (in milk equivalent)	296	283	273	259	88
Cheese and curd*	9,4	9,6	11,7	13,6	145
Butter*	2,8	3,0	1,7	1,4	50
Sour milk products*	19,5	20,9	24,0	25,5	131
Milk*	21,5	21,9	24,0	24,2	113
Per capita purchasing power of average cash disposable income per month					
Butter, kg	35	27	39	44	126
Milk (2,5% fat content), l	265	249	366	410	155
Average retail price of milk and dairy products, Lt/kg					
Butter	12,14	15,67	15,70	18,01	148
Milk (2,5% fat content), Lt/l	1,61	1,71	1,68	1,94	120
Sour cream (20–30 % fat content)	6,66	5,87	6,14	7,28	109
Curd 5–9% fat content)	10,13	10,51	9,86	10,90	108

* Own-produced and consumed products and direct sales excluded.

Sources: *Production of commodities. 2003–2006.* – V.: Department of Statistics to the GovRL; *Agriculture in Lithuania 2007.* – V.: Department of Statistics to the GovRL, 2007; *Household income and expenditure. 2004–2005.* – V.: Department of Statistics to the GovRL; *Household budgets. 2006–2007.* – V.: Department of Statistics to the GovRL, 2007; *Consumer and producer price indices. 2004–2007, q. I–IV.* – V.: Department of Statistics to the GovRL; *MoA Foreign trade data base.*

Major part of dairy products sold on the domestic market are produced in Lithuania. However, the proportion of import is increasing. In 2004 the imported dairy products accounted for 7.6% of all sold dairy products on the Lithuanian market, and in 2008 – for 15.6%. Cheese and fermented and sour dairy products dominate in the structure of import. In total import of milk and dairy products in 2008 amounted to LTL 402,7 million, including 51% of the import value from crude milk.

Producer prices on dairy products on the domestic market in December 2008 increased by 26.2% in comparison to December of 2003. Producer prices were continuously increasing during the entire period of 2004–2007, but have mostly increased in 2005 and 2007. The first strong impetus for the increase of prices on dairy products was the accession of Lithuania to the EU, and the equalization of prices in the common economic area, leading to the rise of prices on the domestic market by 8.2%. The second jump of prices on milk and dairy products took place in 2007 and was influenced by the global boost of prices. In December 2007 production prices on dairy products on the domestic market increased by 23% in comparison to December 2006. In 2008 production prices on dairy products, influenced by the global drop of prices, decreased on the Lithuanian market by 5.5%.

Export of dairy products. Balance of the Lithuanian foreign trade in milk and dairy products during the entire period of 2004–2008 was positive, however, was changing not for the benefit of the Lithuanian milk processing sector. In 2004 export exceeded import by 14.2 times, during the period of 2006–2007 by 4.6 times, and in 2008 – only by 3.3 times. The growth rate of import exceeded that of export: import increased by 7.2 times during the period of 2004–2008, and export – by 67%, and in 2008 import increased by 32%, but export decreased by 4.3%.

In 2008 export of dairy products amounted to LTL 1 328,6 million, or by 4.3% less than in 2007. Export was mostly increasing in 2004 and 2007: by 41% and 36% correspondingly, as compared with the previous years. Such processes were influenced by the common EU market opened for Lithuania in 2004, and the growth of the global demand in 2007. 59% of the value of the exported dairy products in 2008 were created by cheese and curds. In 2007 the proportion of these products has slightly decreased by 12.4 percent points due to the changes in the demand. Next year cheese and curds accounted for half of the total export. Non-concentrated cream accounted for 12.7%, and milk powder – for 7.6% in the structure of dairy products in 2008. In 2008 export of condensed milk increased most – by 5 times, and of condensed milk without sugar – even by 13.6 times in comparison to 2004 (Table 2.24).

Table 2.24. Export of dairy products in 2004–2008, in mill. Lit

CN code	Products	2004	2005	2006	2007	2008	2008 compared to 2004, %
0401	Milk & cream, not concentrated	105,2	137,0	146,9	275,3	180,2	171
0402	Milk & cream, concentrated	110,3	105,3	110,3	230,5	183,8	167
040210	Skimmed milk powder	65,1	71,4	79,2	168,3	79,8	123
040221	Whole milk powder	28,8	2,6	1,3	3,5	21,5	75
040291	Condensed milk without sugar	2,5	9,9	6,6	28,5	34,1	13,6 k.
040299	Condensed milk with sugar	13,9	21,2	23,2	30,0	47,5	342
0403	Fermented or acidified milk & cream	11,0	8,0	9,9	13,8	15,6	142
040310	Yogurt	1,9	1,2	1,8	2,3	2,2	116
0404	Whey & products consisting of natural milk constituents	40,7	53,9	58,1	93,0	58,6	144
0405	Butter & other fats & oils derived from milk, dairy spreads	50,9	66,4	86,1	69,5	52,2	103
0406	Curd & cheese	441,5	477,7	570,9	646,0	782,0	177
040610	Fresh cheese & curd	101,6	120,7	136,8	199,4	268,9	265
040690	Fat cheese	336,8	354,0	431,2	444,0	509,2	151
210500	Ice cream	19,5	22,9	26,2	30,6	31,5	162
350110	Casein	12,3	8,3	3,3	0,9	9,0	73
170211-19	Milk sugar	6,3	9,0	15,8	29,1	15,6	248

Source: MoA. Foreign trade data basis..

Most of Lithuanian dairy products in 2008 were exported to the EU countries – and accounted for 60% of the total export. This share of export was not decreasing during all consecutive years following the accession into the EU. Dominating position among the EU countries belongs to Italy, Germany and Latvia. Support of export of dairy products into Russia increased export to Russia from 19% in 2004 up to 35% in 2006. Later, when in 2007 export subsidies were discontinued, the share of export to Russia remained high due to the established trading relations. Moreover, Lithuanian cheese is sold in Russia under its own trade mark for a higher price than selling it in the EU countries as industrial cheese. In 2008 export of dairy products to Russia accounted for 34% of the total export of dairy products (Fig. 2.26).

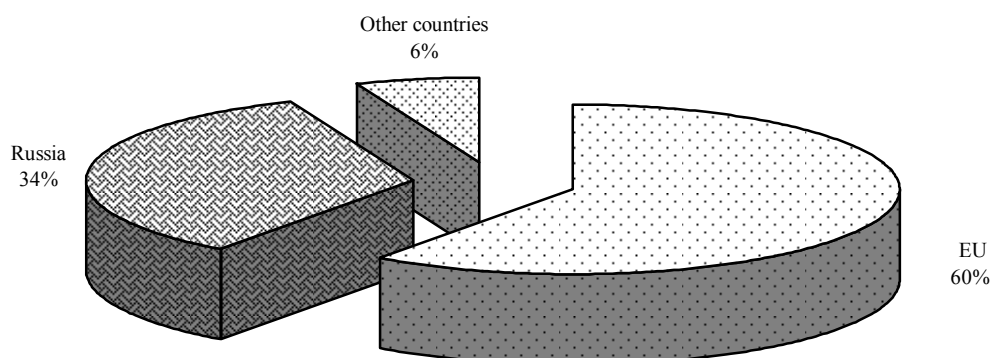

Fig. 2.26. Structure of dairy products by country group in 2008

Source: MoA Foreign trade data base

Market regulation measures. In Lithuania, as in the EU, common market organisational measures on milk and dairy products and milk quota system are applied.

In 2004 the common national milk production quota of 1 647 thousand tons was approved for Lithuania: 1 280 thousand tons on sales for processing, and 367 thousand tons for direct consumption. Since the quota period of 2006–2007 (quota year starts on 1 April and continues until 31 March of the following year) it has been increased by 57,9 thousand tons, and from the quota year of 2007–2008 for 2% more (up to 1 739 thousand tons). The allocated quota is sufficient and does not restrict the commercial production. Quota on sales for processing of 2004–2005 was fulfilled by 92%, of 2005–2006 by 82%, of 2006–2007 and 2007–2008 by 85%, and of 2008–2009 by 84%. Quota on direct consumption of 2004–2005 was fulfilled by 19%, of 2005–2006 by 44%, and of 2006–2007 by 34%, and of 2007–2008 by 54%. Direct payments for the quota milk sold in 2004 amounted to LTL 48,3 million, in 2005 – to LTL 50,8 million, in 2006 – to LTL 56,0 million, in 2007 – to 70,4 million, and in 2008 – to 119,6 million.

Export refund compensations were most widely used measures from the package of measures on common market regulation organisation in 2004–2007. In 2004 milk processing companies received LTL 1,4 million of export refund payments for the export of dairy products to third countries, in 2005 – LTL 47,3 million, in 2006 – LTL 73,9 million, in 2007 – LTL 71,6 million. Following the increased global prices on dairy products the EU export refund payments for the export of dairy products to third

countries were withdrawn since July 2007. However, milk processing companies received yet LTL 3,8 million of subsidies in 2008 for the exported production in previous years. From other common market organisational measures on milk and dairy products support for private storing of long-term maturation cheese was mostly used: support was annually allocated to two companies for storing of 700 tons of cheese. Interventive purchase of butter and skimmed milk powder were not administered at all, as there were no dairy companies willing to sell their production to interventive warehouses. Other common market organisational measures on milk and dairy products were hardly used.

Economic indicators of the dairy sector. In 2004–2007 milk production at specialized dairy farms was profitable. According to the FADN data on respondent farmer farms, main income of which was income from milk production, the average profitability in 2004 accounted for 57%, including subsidies for production, and 35% subsidies exclusive. In 2007, because of the increased prices on resources, the profitability decreased to 50%, subsidies inclusive, and 30%, subsidies exclusive. Milk production was profitable also for agricultural partnerships and enterprises, though profitability in 2007 was the lowest during the period of 2004–2007, accounting for 24.6% (Fig. 2.27). Milk production in agricultural partnerships and enterprises remained among the most profitable branches of the economy, however, the gap from the average profitability of the agricultural production output has obviously decreased: from 19 percentage points in 2004, 32% in 2005 to 10 percentage points in 2007.

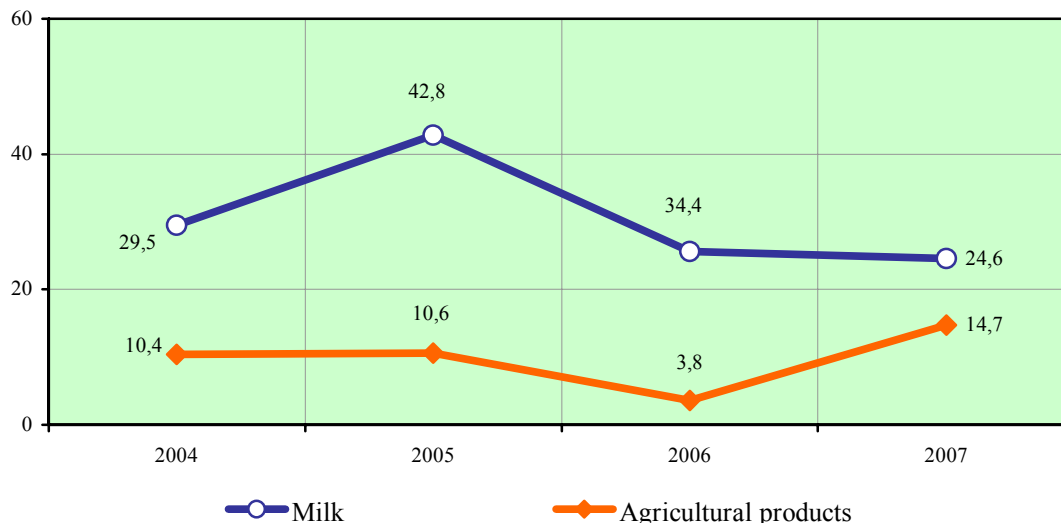

Fig. 2.27. Profitability of milk and all agricultural products in agricultural companies and enterprises in 2004–2007, in per cent

Source: Aggregated data of Official statistical forms of agricultural companies and other agricultural enterprises. 2004–2007,

Profitability of milk production was decreasing because of the increasing cost price of products. In 2004 the average cost price of the dairy production output in agricultural partnerships and enterprises was LTL/t 463, calculated by the reckoned

weight, and in 2007 increased up to LTL/t 540, i.e. by 17%. The cost price of liquid milk increased by 36%.

Activities of the four major dairy companies of Lithuania enrolled in the list of the Vilnius exchange of securities referred as profitable until 2007, incurred losses of 1.9% (Table 2.25). The highest profitability of 5.3% was reached in 2007.

Table 2.25. Net profitability of major dairy enterprises in 2004–2008, in per cent

Indicator	2004	2005	2006	2007	2008
Net profitability	4,9	3,6	3,1	5,3	-1,9

Source: NASDAQ OMX [interactive], [visited on 18 May 2009]. Access through Internet: <http://www.nasdaqomxbaltic.com/market/?pg=reports>.

In 2004–2007 the profitability was greatly influenced by the possibility to sell dairy products on the common EU market, and by the EU export refund payments for dairy products sold to third countries. In 2007 the profitability increased through the rise of global prices on dairy products. In 2008 subsidies for export to third countries were discontinued, and the global prices on dairy products were notably decreasing. Such situation was detrimental to Lithuanian milk processing enterprises exporting more than half of their output.

3.3. Meat

Meat production within the structure of agricultural and food production of Lithuania decreased in 2008 almost by 8 percentage points and accounted for 16.7% of the total agricultural income. Farmers and partnerships gained most of income from raising pigs (38%) and cattle (31%). A considerably cheaper feeding grain of the 2008 harvest and the expanding Russian markets made livestock breeding a profitable business again. Though in 2008 purchase prices on livestock increased, contrary to 2007, foreign trade balance in meat and livestock was negative.

Livestock breeding. Within the period of 2004 – 2008 the number of poultry and sheep increased, and the number of cows and pigs – decreased. During the year of 2008 the number of almost all animals decreased (Table 2.26).

Table 2.26. Number of livestock and poultry in 2004–2008 (at the end of the year)

Kind of animals	2004	2005	2006	2007	2008*
Cattle	792,0	800,3	838,8	787,9	771,0
of which dairy cows	433,9	416,5	399,0	404,5	394,7
Pigs	1073,3	1114,7	1127,1	923,2	897,1
Poultry	8419,4	9397,1	9439,9	9874,8	9100,0
Sheep	22,1	29,2	36,6	43,3	51,3

* Preliminary data.

Sources: *Number of Livestock 2008*. – V.: Department of Statistics to the GovRL, 2008;
Agriculture in Lithuania 2006. – V.: Department of Statistics to the GovRL, 2007.

87% of cattle and 97% of sheep are raised in farmers' and family farms, and even 80% of poultry and 61% of pigs are raised at agricultural partnerships and enterprises. Most of cattle are kept in the farms of Šilalė, Kelmė and Šilutė regions, most of cows in the regions of Šilalė, Šakiai and Kelmė, and most of pigs are raised in the regions of Panevėžys, Jonava and Joniškis, while poultry – in the regions of Kaišiadoriai, Elektrėnai and Vilnius, of sheep and goats – in the Anykščiai, Rokiškis and Molėtai regions.

Cattle. According to the data of the Department of Statistics to the GovRL, 394,7 thousand of dairy cows were kept in Lithuania by the end of 2008 – 51% of the total cattle herd (Fig. 2.28). The most popular breeds of cows currently raised in Lithuania are the Lithuanian black-and-white (73%) and the Lithuanian red (23%). Beef and cross-breed cows account only for 4% in Lithuania.

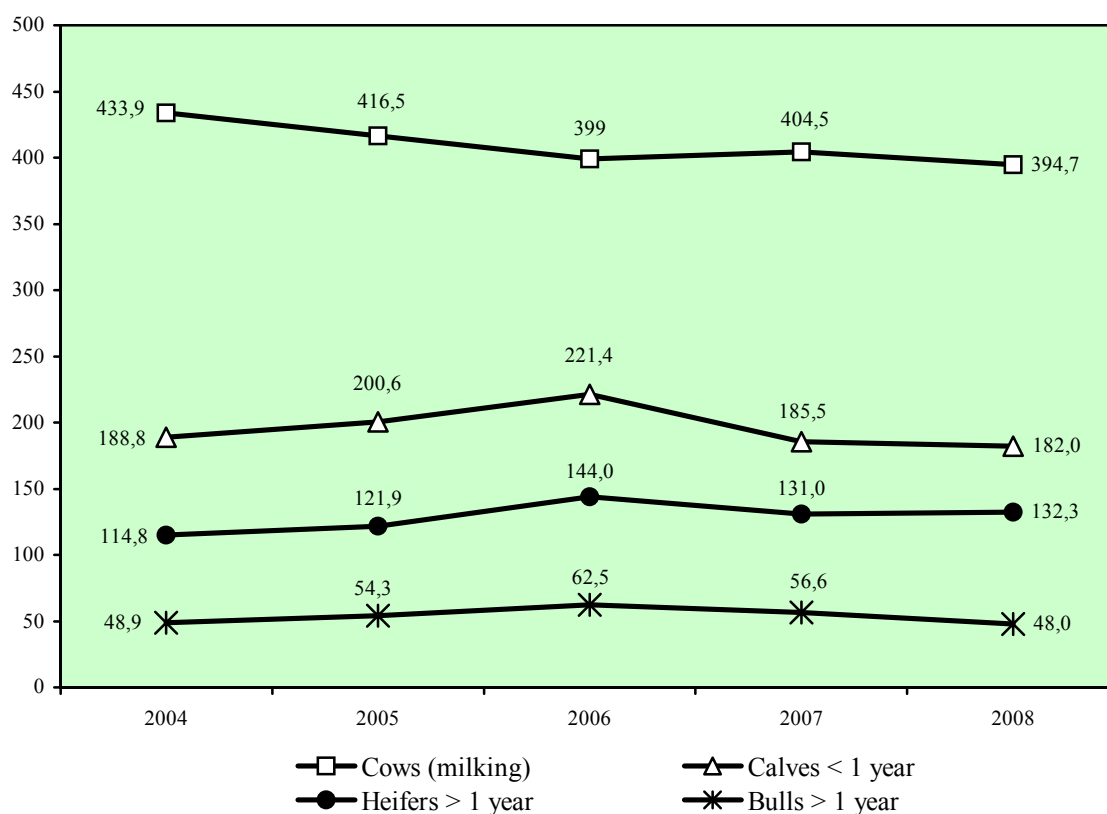

Fig. 2.28. Number of cattle in 2004–2008 (at the end of the year), in thousand

Source: Number of livestock. 2004–2008. – V.: Department of Statistics to the GovRL.

By the end of 2008 the number of pedigree heifers and calves amounted to 214,6 thousand, and to 19,0 thousand of bulls. Young cattle for meat (calves, bulls and heifers for slaughter) by the end of the year accounted only for 17% of the total cattle herd (decreased by 19% in a year). The largest proportion among young cattle consisted of calves younger than 1 year – 53%, and bulls from 1 to 2 years – 41%.

The number of beef and cross-breed cattle in recent years increased: the number of suckler cows increased more than by 4 times, up to 15,5 thousand heads, however, cows of beef breeds account only for 4% of the total cattle herd. In 2008 the number of beef and cross-breed heifers amounted to 35 thousand and accounted for 27% of the total number of cattle in this group.

By the end of 2008 cattle was raised in 123,6 thousand farms (Table 2.27), i.e. by 11% less than a year ago. On the average 5.9 heads of cattle were raised per farm (in the EU-25 – approx. 37 heads). The smallest farms among the EU-25 member states are in Lithuania, Latvia and Poland (7 heads per farm), and Slovenia (11 heads). More than half of farms (62%) kept 1–2 heads of cattle accounting for 14% of the cattle herd. On slightly larger farms (from 3 to 10 heads) 24% of the total number of cattle was raised. Farms raising 51 and more heads of cattle accounted only for 1.4%, however, almost one third of the total number of cattle was raised there. Farms raising beef cattle are even smaller – only 3 heads of cattle per farm. Almost $\frac{3}{4}$ of farms kept 1–2 heads of cattle.

In 2006–2008 export of calves accounted for 38%. This was the main reason for the decreasing numbers of heifers and bulls. The number of cows was decreasing as the milk yield was increasing.

Table 2.27. Farms by number of cattle and beef cattle in 2008 (at the end of the year)

Number of cattle per farm	Cattle		Beef cattle	
	number of farms	number of cattle	number of farms	number of cattle
1–2	76194	102687	22175	27898
3–5	25479	93940	5048	18415
6–10	10842	81424	1660	12213
11–20	6071	87533	645	9220
21–30	1848	45887	170	4225
31–50	1489	57598	142	5528
51–100	1052	72268	88	6059
101–150	277	33244	24	2884
>=151	359	156669	24	5481
Total	123611	731250	29976	91923
Average		5,9		3,1

Source: Data of the Agricultural Informati and Rural Business Centre.

While the number of beef and cross-breed cattle is small, beef production sector depends on the tendencies in the sector of milk production. The herd of dairy cows is not adequate to the consumption of beef and is actually increasing the supply. Meat processing manufacturers take the advantage and reduce purchase prices. Consequently, trade in calves is partly reducing the supply. The quality of young dairy cattle carcass is worse. In 2008 most cows and bulls were purchased (39% of each). Findings of the assessment of carcass meat indicate, that class E, U and R taken together accounted only for 9%, class O – for 48%, and class P – for 43%. In the group of young bulls most of cattle purchase (58%) was in class O, in the group of cows (69%) – in class P, heifers (65%) – in class O, while in the EU carcass in class U and R are prevailing. Poor meat quality of dairy cattle breeds influences the quality of meat products.

Pigs. According to the data of the Department of Statistics to the GovRL, by the end of 2008 about 897,1 thousand of pigs were raised on the farms of Lithuania. This accounts for 3% less than in 2007 (Table 2.28). During the period of 2003–2008 the number of pigs in farmers’ farms decreased by 40%, and in agricultural partnerships and other agricultural enterprises increased by 23%. The period of 2007–2008 was loss-making for pig producers, subsequently, pig herds started decreasing.

Table 2.28. The number of pigs in 2004–2008 (at the end of the year), in thousand

Groups of pigs	2004	2005	2006	2007	2008
Piglets	462	494,6	510,5	396,9	401,8
Pigs for fattening	513,6	519,4	517,1	443,4	416,0
Breeding pigs	97,7	100,1	99,5	82,9	79,3
Total	1073,3	1114,1	1127,1	923,2	897,1
In agricultural companies and enterprises, %	45,2	49,2	54,1	61,2	...

Source: Data of the Department of Statistics to the GovRL.

The quality of pig carcass is annually improving (Table 2.29). In 2008, as compared with 2004, the comparative weight of the quality of class S and E carcass muscularity increased by 18 per cent points. According to the quality of purchased carcass Lithuania is not behind other EU member states.

Table 2.29. Pig carcass quality by SEUROP conformation class in 2004–2008, in per cent

Class	2004	2005	2006	2007	2008
S	15	20	22	30	34
E	47	46	47	46	46
U	27	25	23	19	16
R	9	8	7	4	3
O	2	1	1	1	1
P	0	0	0	0	0
Total	100	100	100	100	100

Source: Data of the SE „Animal productivity control“.

Sheep and goats. According to the data of the Information Centre on Agriculture and Rural Enterprise, by the end of 2008 about 51,3 thousand heads of sheep, including 23,3 thousand of ewes, were raised in 3,8 thousand farms, and 7,4 thousand of goats, including 3,5 thousand of yearling goats, were raised in 3,5 thousand farms. Within the period of 2004–2008 the number of sheep increased by 47%, and the number of goats – by 8%. Sheep breeding is not a very popular branch of agriculture in Lithuania, because of non-existing consumption traditions of this sort of meat. The per capita consumption of sheep meat in the EU amounts to 2,8 kg on the average, and in Lithuania by 14 times less. Financial support to farms for acquiring new sheep breeds is insufficient, while the larger part of sheep is kept in small farms (Table 2.30).

Table 2.30. Farms by numbers of sheep and goat in 2004 and 2008 (at the end of the year)

Number per farm	Sheep farms				Goat farms			
	2004		2008		2004		2008	
	farms	sheep	farms	sheep	farms	goats	farms	goats
1–2	1087	1533	1638	2349	3183	4034	2923	3779
3–5	597	2247	896	3356	410	1413	504	1786
6–10	393	3073	511	3855	46	336	91	667
11–20	290	4206	347	5135	14	192	17	257
21–30	151	3749	146	3707	3	70	5	120
31–50	95	3587	145	5479	2	75	2	82
51–100	58	3946	100	6876	1	65	2	124
101–150	15	1751	19	2297	2	263	0	0
>=151	23	10774	37	18273	1	362	2	571
Total	2709	34866	3839	51327	3662	6810	3546	7386
<i>Average</i>		13		13		2		2

Source: Data of the Agricultural Information and Rural Business Centre.

In 2008 the number of raised and slaughtered sheep reached 29,5 thousand heads (output – 0,5 thousand tons of mutton), and of goats – 20 thousand heads. However, only some 4% of this kind of animals were purchased by slaughterhouses. The average purchase price on live weight of sheep and goats in 2008 was by 25% higher than in 2007.

Poultry. By the end of 2008 the number of various kinds of poultry raised in the country amounted to 9,1 million, including approximately 97% of chicken. The number of poultry during the period of 2004–2008 increased by 8%. Lower retail prices on Polish poultry had a great impact on the number of poultry in 2008.

Table 2.31. Number of poultry by kind in 2004–2008 (at the end of the year), in thou. heads

Kind of poultry	2004	2005	2006	2007	2008*
Chicken	8227,8	9201,3	9233,8	9692,8	8800,0
layers	4219,3	4377,3	4385,6	4309,6	4300,0
broilers	4008,5	3024,8	3636,5	4289,8	3800,0
Turkey	93,4	103,0	116,5	104,4	100,0
Goose	51,5	47,9	44,2	36,9	35,0
Ducks	45,5	41,0	35,8	34,3	33,0
Other	1,2	3,9	9,6	6,4	6,0
Total	8419,4	9397,1	9439,9	9874,8	9100,0

* Preliminary data.

Source: Data of the Department of Statistics to the GovRL.

Meat production. In 2008 meat production from all farms amounted in total to 219 thousand tons of animal and poultry carcass meat, accounting for 13% less than in 2007 (Fig. 2.29). Pork and beef production decreased almost by one fourth, as pork and cattle herds were reduced because of high increase in prices on feedstuffs.

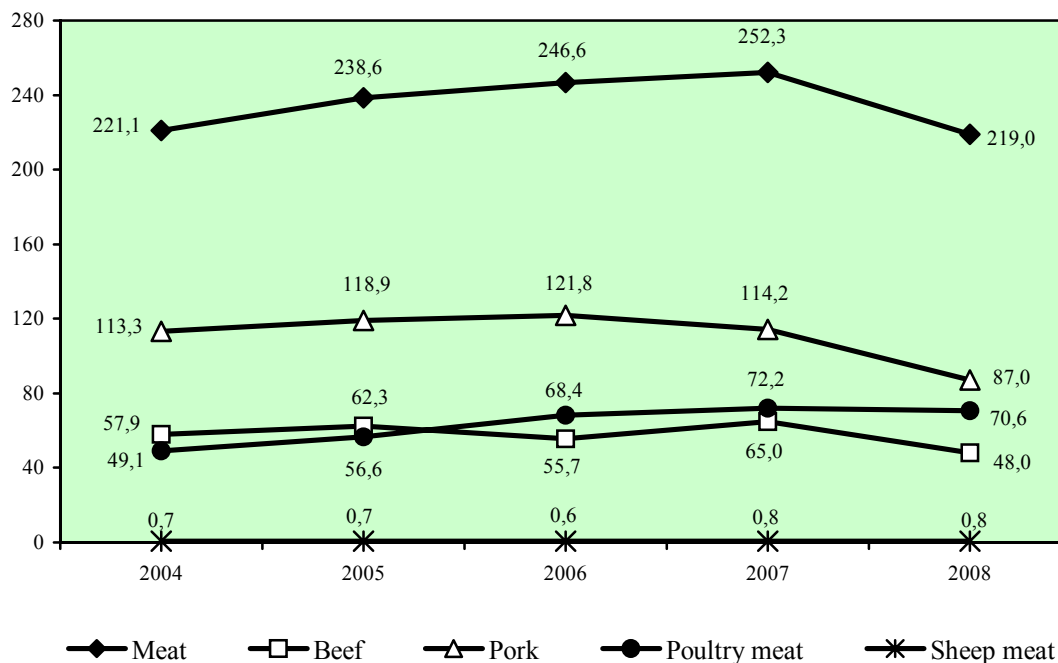

Fig. 2.29. Meat production (carcasses) in 2004–2008, in thousand tons

Sources: Lithuania in Figures, 2009. – Vilnius: Department of Statistics to the GovRL, 2009;
Agriculture in Lithuania. 2007 – Vilnius: Department of Statistics to the GovRL, 2008.

Pork production in 2008 accounted for 40%, poultry – 32%, and beef – 22%. The volume of beef and poultry production was slightly increasing, and of pork – decreasing.

The volume of purchased livestock and poultry in 2008 amounted to 241,8 thousand tons (live weight), accounting for 11% less than in 2007. Slaughterhouses and meat-packing-plants purchased 184,9 thousand tons of cattle (by 15% less than in 2007), producing 43,4 thousand tons of carcass meat. Mostly cows were purchased (39%), but almost equally of cow-meat and beef according to the carcass weight (17 thousand tons of each). Purchases of calves in 2008 were by 16% less than in 2007.

The average purchase price of cattle in 2008 was almost by 22% higher than in 2007 (Fig. 2.30).

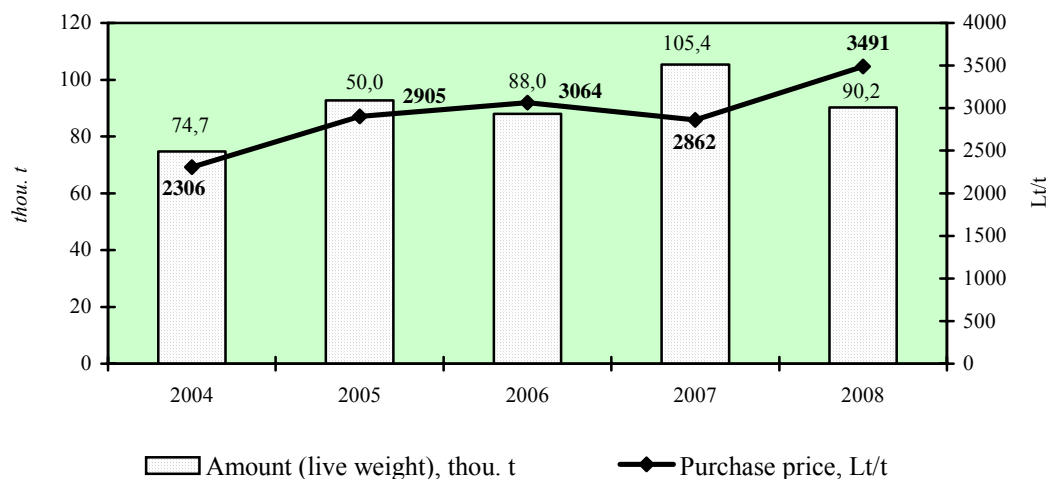

Fig. 2.30. Amounts purchased and average prices of cattle in 2004–2008

Sources: *Agriculture in Lithuania 2007*. – V.: Department of Statistics to the GovRL, 2008;
Purchase of agricultural products. Jan 2008. – V.: Department of Statistics to the GovRL, 2008.

Purchase prices on cattle in Lithuania are significantly lower than the EU average (Table 2.31). Lithuania is not much behind the neighbouring Poland by purchase prices on cattle, but approx. 20% behind the EU average, yet.

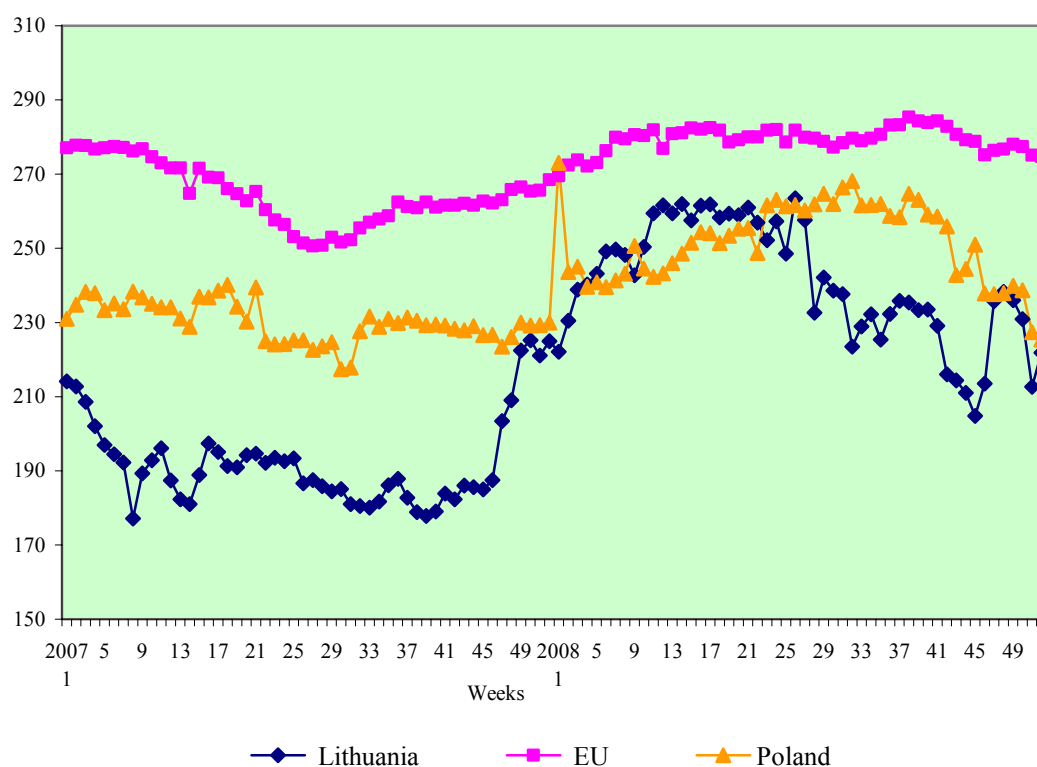

Fig. 2.31. Purchase price of bulls O3 in Lithuania, Poland and the EU average in 2007 and 2008, in Euros per 100 kg

Source: *Data of the European Commission*.

In 2008 slaughterhouses and meat-packing-plants purchased 45% (610 thousand) of pigs raised in all farms of the country, at the average purchase price of LTL/t 4385, by 22% higher than in 2007 (Fig. 2.32).

Purchase price on pigs in Lithuania (class E) by the end of 2008 was by 15% higher than the EU average, and almost by 11% higher than in Poland (Fig. 2.33). By the end of 2008 the highest purchase prices were in Greece, Malta and Bulgaria, and the lowest – in Denmark, the Netherlands and Sweden. In 2008 purchase prices on pigs were the highest since 2001.

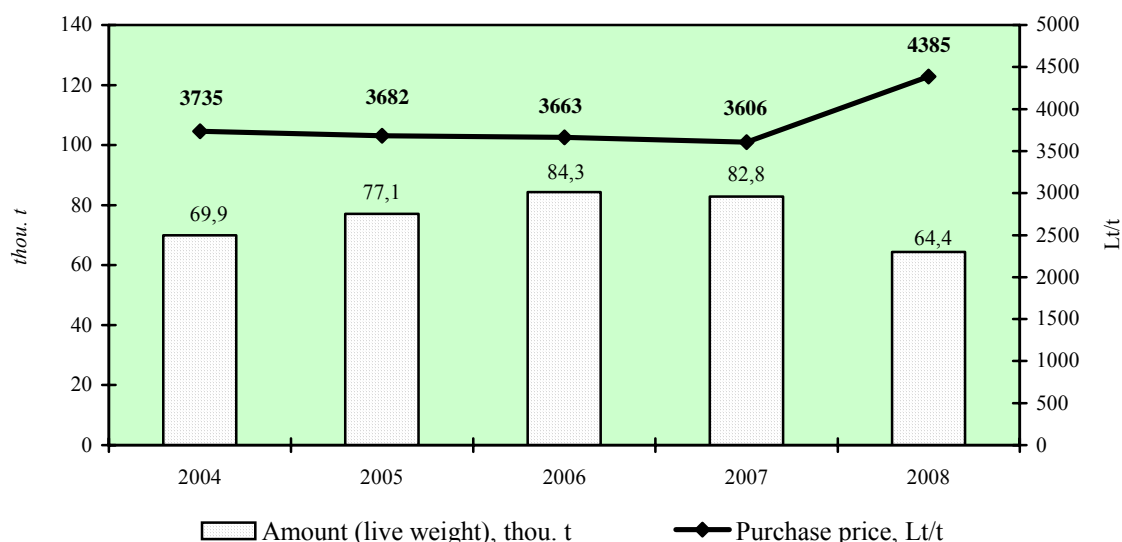

Fig. 2.32. Amounts purchased and average price of pigs in 2004–2008

Sources: *Agriculture in Lithuania 2007*. – V.: Department of Statistics to the GovRL, 2008;
Purchase of agricultural products. Jan 2008. – V.: Department of Statistics to the GovRL, 2008.

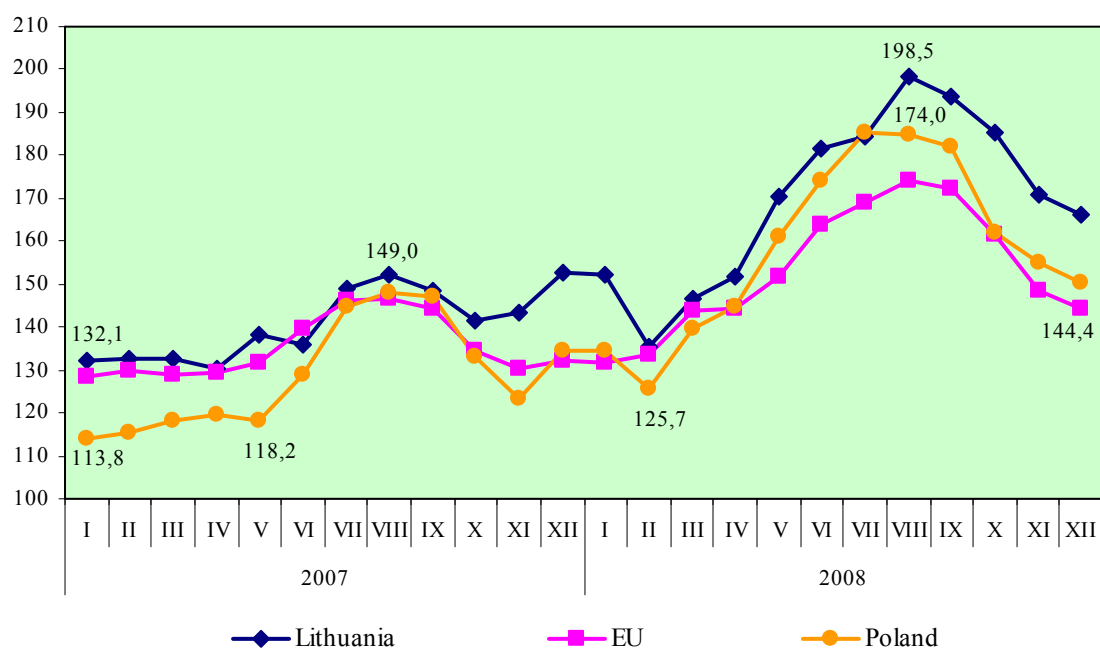

Fig. 2.33. Purchase price of pigs in Lithuania, Poland and EU average in 2007 and 2008, in Euros per 100 kg

Source: Eurostat data.

About 41,6 million heads of poultry was slaughtered in 2008 (by 6% more than in 2007), including 36,4 million of broiler chicken. The average purchase price on poultry increased by 10% in comparison to 2007. The increasing price on grain and the growing demand in poultry meat influenced in the main the rise of prices on poultry meat. Only by the end of the year, when prices on feeding grain and other production resources dropped, the price on poultry meat also started decreasing.

In 2008 the price on chicken carcass, as compared with 2007, was increasing by approximately 2% in all EU countries. The highest jump in prices was fixed in the Check Republic – by more than 23%, but in some countries the price on chicken meat has slightly dropped, namely, in Italy (by 1.0%), Romania (by 1.7%), the United Kingdom (by 7.5%), and Spain (by 9.8%). The United Kingdom distinguished by the cheapest price on chicken carcass in 2008 (by 25% cheaper than the EU average). The highest price was in Cyprus (by 36.6% more than the EU average).

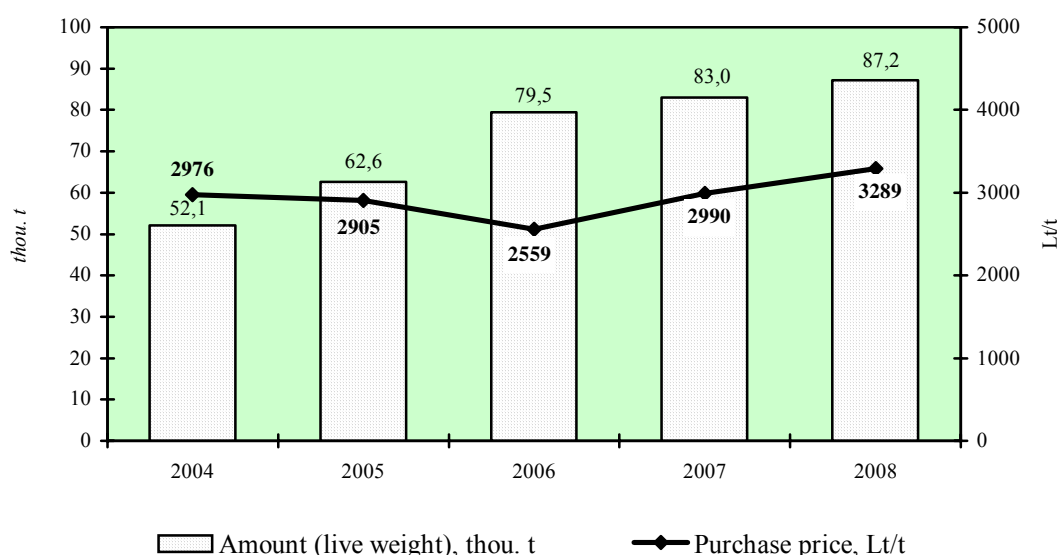

Fig. 2.34. Amounts purchased and average prices on poultry in 2004–2008

Sources: *Agriculture in Lithuania 2007.* – V.: Department of Statistics to the GovRL, 2008;
Purchase of agricultural production by 1 Jan 2008. – V.: Department of Statistics to the GovRL, 2008.

The price on chicken meat in Lithuania is among the lowest in the EU. Lithuanian market is greatly influenced by the import of chicken from Poland, the price of which is by 20% lower.

Processing. National meat-packing-plants produced from the purchased livestock and imported meat in 2008 about 183,1 thousand tons of meat and meat products – by 12% more than in 2007 (Table 2.32). Production of poultry and pork in 2008 was rapidly increasing, while of beef, in comparison with 2007, decreasing.

Table 2.32. Production of main meat products in 2004–2008, in thousand tons

Product	2004	2005	2006	2007	2008*
Meat and meat offal	116,9	155,7	163,8	183,1	...
Beef and veal	31,4	44,8	41,8	43,9	37,1
Pork	48,1	64,3	63,4	67,6	76,1
Poultry meat	27,6	35,8	44,4	51,7	74,9
Sausages and smoked products	73,5	76,3	76,7	71,0	69,8

* LIAE calculation.

Source: *Agriculture in Lithuania 2007*. – V.: Department of Statistics to the GovRL, 2008

Domestic market. In 2008 the production output of national meat-packing-plants on the domestic market accounted for 29% of beef, 81% of poultry and 95% of pork. For a long time retail prices on meat products were alternating slowly depending in the main on livestock purchase prices. However, since the beginning of 2008 (Fig. 2.35), the retail price on beef increased by more than one third, and within the year of 2008 the growth of the price on beef, in comparison with 2007, accounted for almost 50%, whereas the purchase price on cattle during the same period increased only by 20%. As the share of meat processing enterprises (Fig. 2.36) was not changing at such a significant rate, by the end of 2008 the share of commercial companies within the retail price structure increased, and was the largest (44%). About 30% of the retail price on beef increased because of reasons known only to commercial companies.

Changes in retail prices on pork took place at the end of 2007 and in June 2008, however, the growth of retail prices were in the main related to the growth of purchase prices on pigs (Fig. 2.37). In the structure of retail prices on pork (Fig. 2.38) the share of meat processing enterprises (involved in the process of pig slaughtering and meat processing) is not large (9% – 13%), of pig raising and commercial companies – almost similar. By the end of 2008 the share of pig producers was the largest – 43%, but decreased within a year by 9 per cent points, while the share of commercial companies was not significantly smaller (40%), as increased within a year by 6 per cent points.

In the structure of retail prices on chicken, producer (poultry farms) prices increased by far less rate than the price of commercial companies (Fig. 2.39). The average sale-price of producers in 2008, as compared with 2007, increased by almost 10%, but commercial companies increased them by 22%. Within the period of 2007–2008 the share of producers decreased by 9 per cent points, and the share of commercial companies increased by the same proportion (Fig. 2.40).

By the end of 2008 the RL Seimas passed the decision to increase value added tax rate and withdraw tax exemptions that were granted on some food products, therefore price changes on meat products are anticipated.

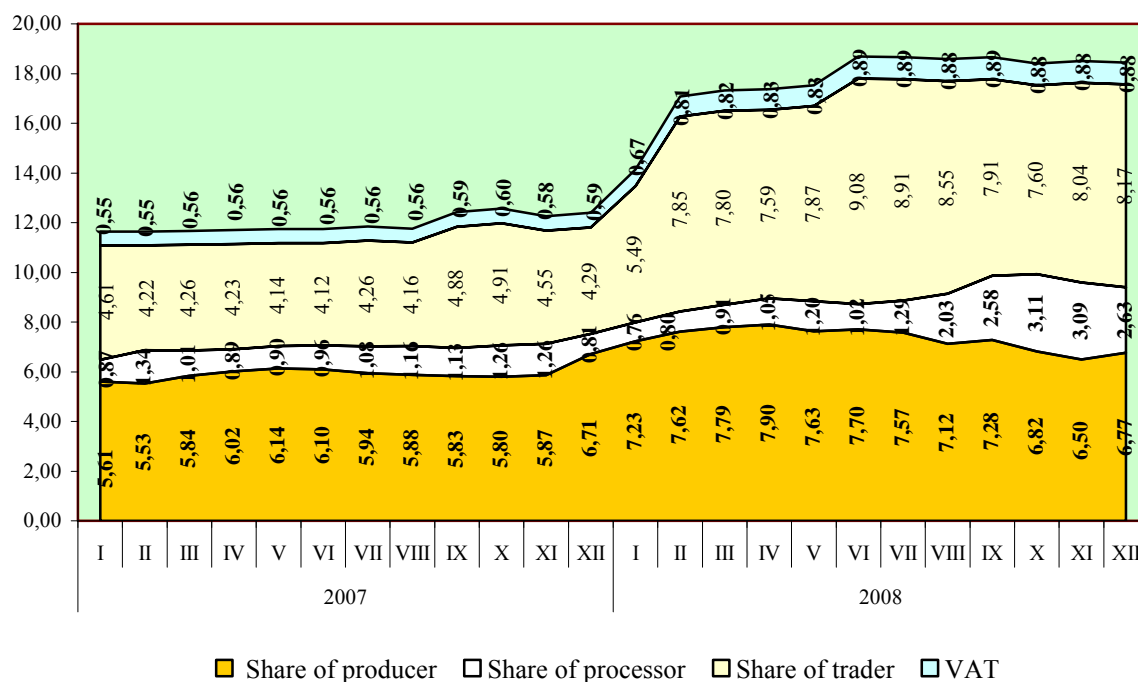

Fig. 2.35. Beef price chain in 2007–2008, in Litai per kg

Source: Department of Statistics to the GovRL
AFMIS data - Agriculture and Food Market Information System

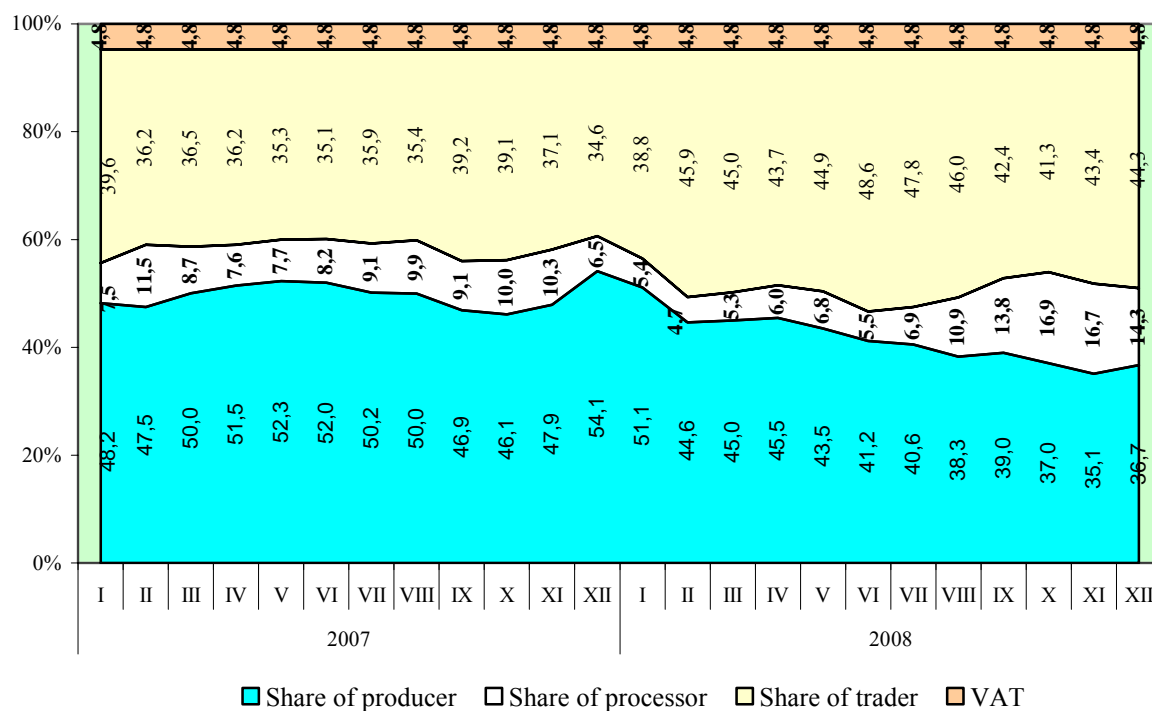

Fig. 2.36. Beef price chain in 2007–2008, in per cent

Source: Department of Statistics to the GovRL
AFMIS data - Agriculture and Food Market Information System

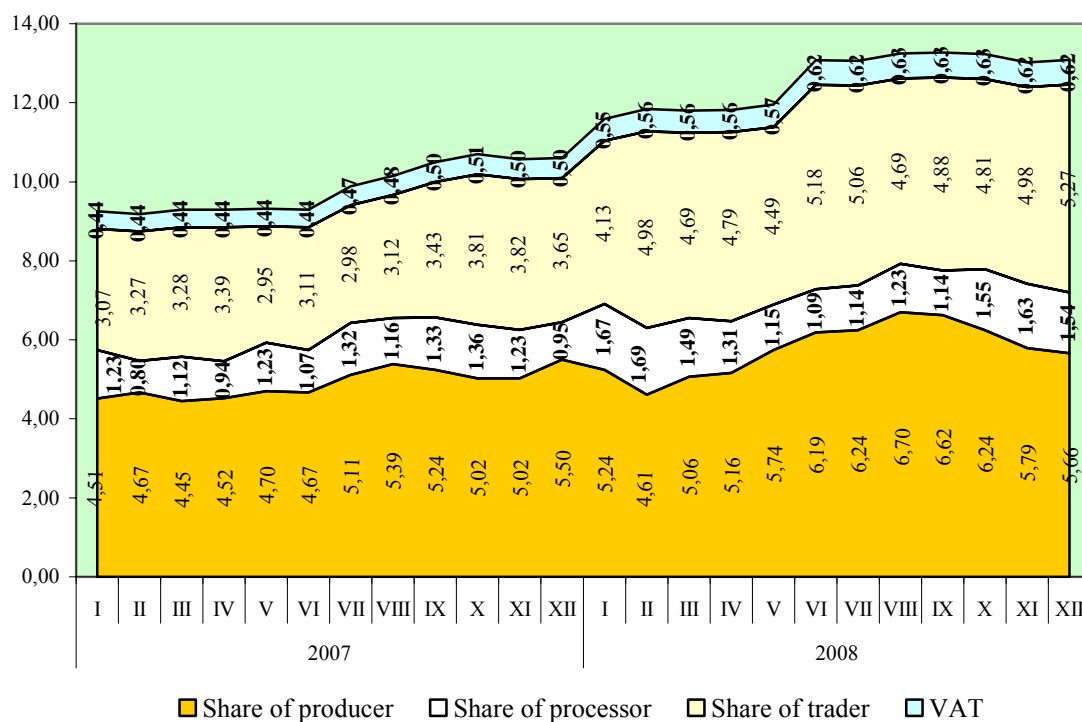

Fig. 2.37. Pork price chain in 2007–2008, in Litai per kg

Source: Department of Statistics to the GovRL
AFMIS data - Agriculture and Food Market Information System

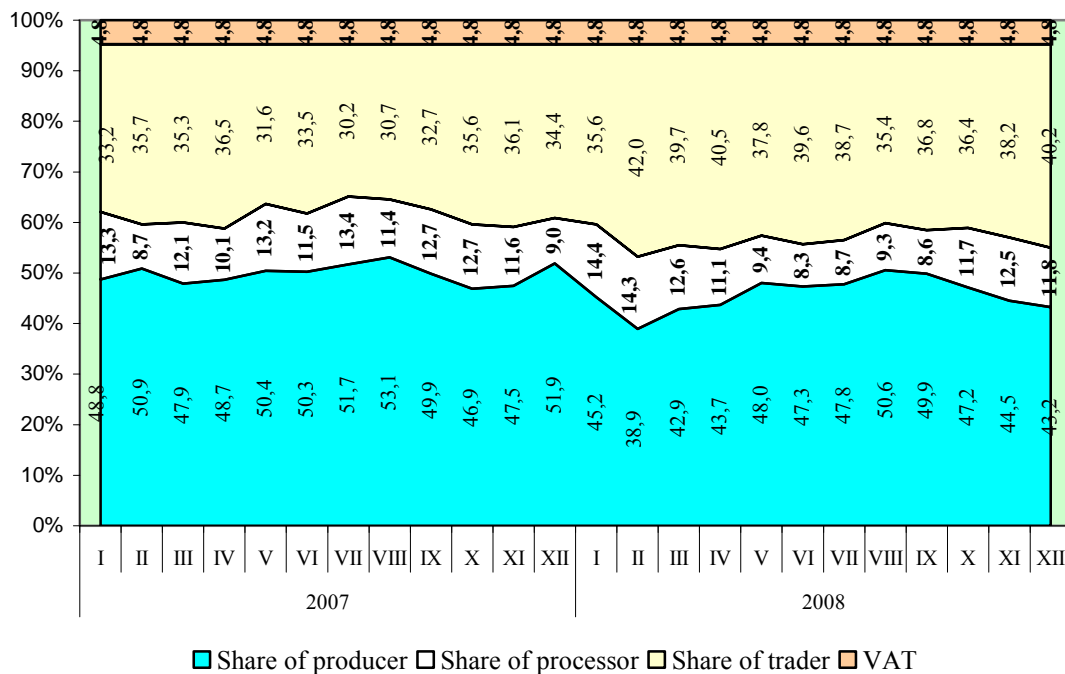

Fig. 2.38. Pork price chain in 2007–2008, in per cent

Source: Department of Statistics to the GovRL
AFMIS data - Agriculture and Food Market Information System

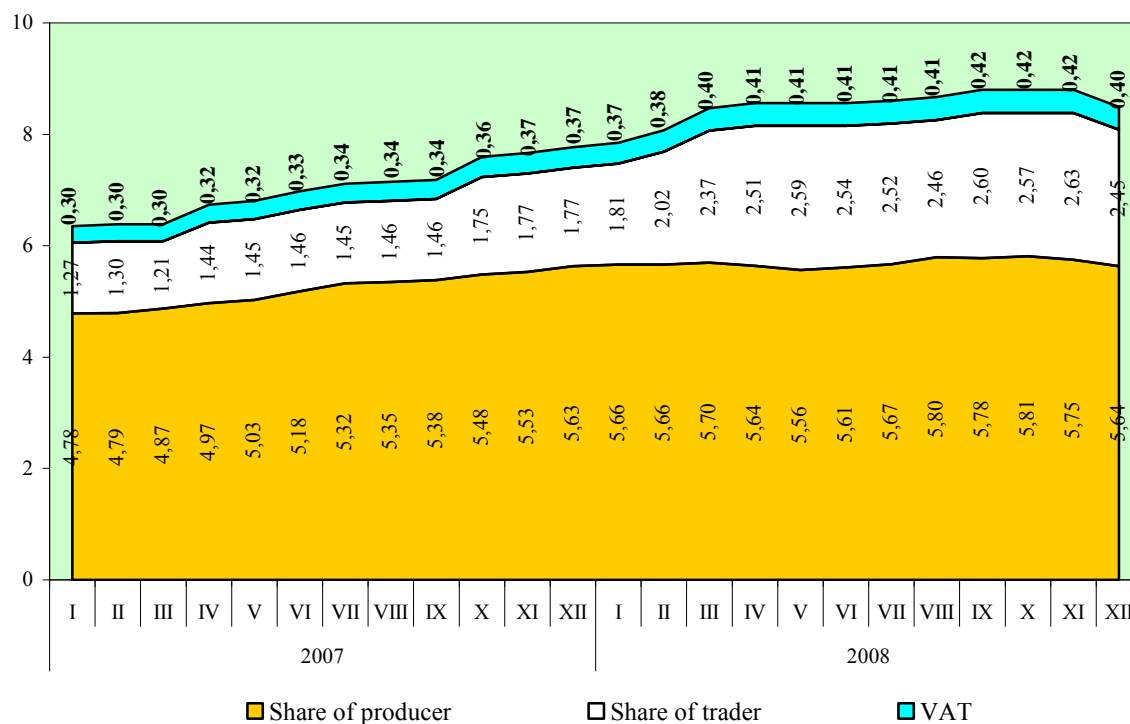

Fig. 2.39. Chicken meat price chain in 2007–2008, in Litai per kg

Source: Department of Statistics to the GovRL
AFMIS data - Agriculture and Food Market Information System

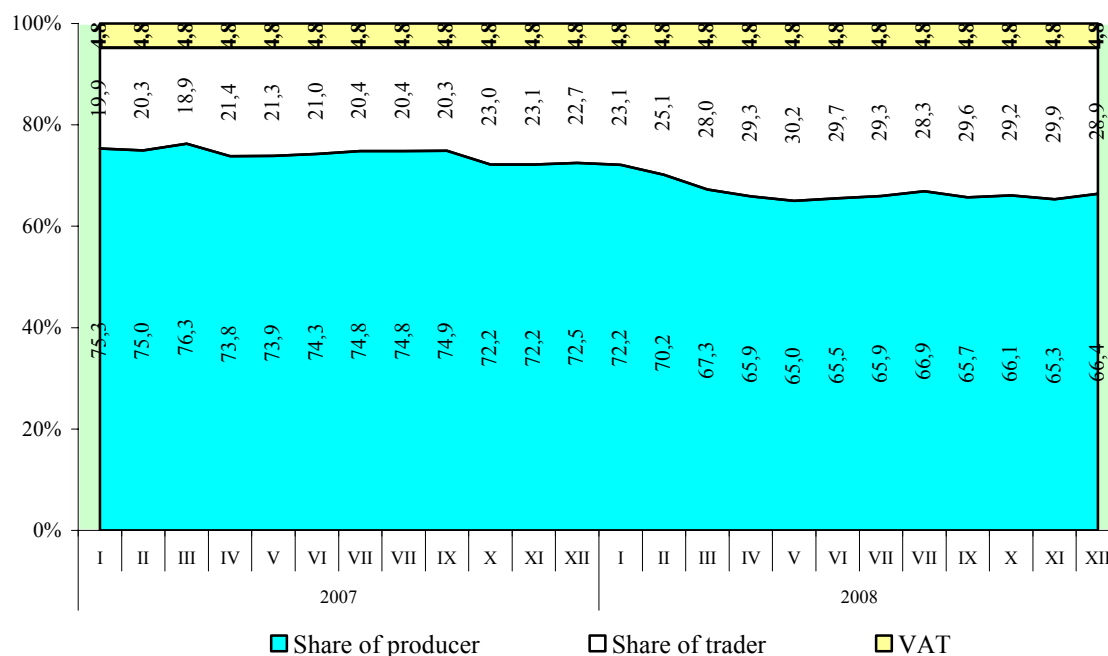

Fig. 2.40. Chicken meat price chain in 2007–2008, in per cent

Source: Department of Statistics to the GovRL
AFMIS data - Agriculture and Food Market Information System

In 2003 annual per capita consumption in Lithuania amounted to 59 kg of meat and meat products (including category I and II meat offal), and in 2007 – 77 kg (Table 2.33). The EU-25 average annual per capita consumption of meat and meat products was by one fifth higher – 91 kg.

Table 2.33. Per capita consumption of meat products in 2004–2007, in kg

Meat by kind	2004	2005	2006	2007
Meat, total	70	73	72	77
of which:				
beef	10,6	8,0	8	7,4
pork	35,9	40,1	40	45,6
poultry	17,4	21,8	22	21,9
sub-products, category I and II	5,7	2,3	2,4	1,6

Source: *Agriculture in Lithuania. 2007.* – V.: Department of Statistics to the GovRL, 2008.

Meat consumption in 2008 did not change much. The most popular kind of meat in Lithuania is pork. In 2007 per capita consumption of pork was almost 46 kg, i. e. by 3 kg more than the EU average – 43 kg. Most of pork is consumed in Spain (61 kg), Denmark and Austria (58 kg). The consumption of poultry in Lithuania is almost by half less than of pork. In comparison to the EU member states (the average is 23 kg) the consumption of poultry is quite similar. Most of poultry is consumed in Ireland (32 kg), in Spain and in Portugal (30.5 kg in each). Beef consumption in Lithuania amounts only to 7.4 kg. Less of beef is consumed in Poland and Hungary. In some new EU member states beef consumption is decreasing due to the most rapidly increasing prices on beef under the common market conditions. Most of beef is consumed in Denmark (29 kg), France and Sweden (26 kg in each).

According to the 2007 meat balance, Lithuania has beef provisions in stock by 179%, pork – by 79%, and poultry – by 83% (Table 2.34). In 2008, following the reduction in the production of all sorts of meat, provisions in the said products may also decrease by some 10%.

Table 2.34. Meat self-sufficiency level in selected EU countries in 2007, in per cent

Country	Beef	Pork	Poultry
France	105	106	122
Germany	119	99	92
United Kingdom	75	46	92
Netherlands	113	245	195
Ireland	683	153	95
Denmark	83	625	140
Sweden	58	82	80
Finland	90	119	105
Poland	193	100	112
Lithuania*	179	79	83
Latvia	101	52	42
EU-27	99	108	103

* 2008

Sources: *Vieh und fleisch, ZMP, 2008.*

Foreign trade. In 2008 some 71% of meat and 38% of live animals were exported to the EU member states. In 2008 Lithuanian foreign trade balance in meat has become negative again (Fig. 2.41). During the period of 2004–2008 the volume of meat export increased by 7 times, and import – by 3.5 times. Export of live animals exceeded import by 3.5 times, and accounts for almost one third of the total export of meat.

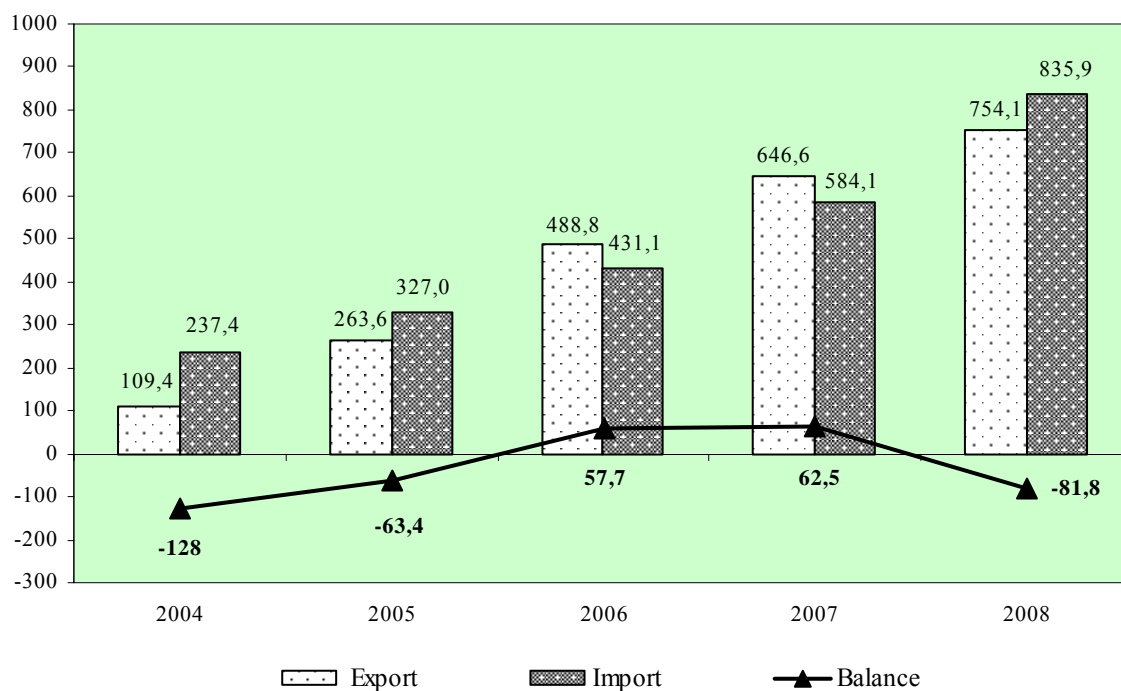

Fig. 2.41. Balance of foreign trade in meat, in 2004–2008, in million Litass

Source: MoA Foreign trade data base (Data of the Department of Statistics to the GovRL).

According to the data of the Department of Statistics, export in 2008 amounted to 25,7 thousand tons of beef for LTL 261,5 million, accounting for 16% less than in 2007, though in the value expression by 4.5% more (Table 2.35). Most of beef (by value expression) was exported to Russia (44%), the Netherlands and Sweden (10% to each). 49% of beef was exported to the EU member states.

Export of calves was no longer increasing in 2008. According to the data of the Centre of Agricultural Information and Rural Enterprise, 139 thousand heads of calves were exported in 2008, accounting for 6% less than in 2007. Almost 85% of calves were exported to the Netherlands, Spain, Poland and Israel. Export of calves by value expression accounts for 11% of the total export in the meat sector.

Export refund payments for beef export to third countries in 2008 amounted to LTL 23,7 million, as much as in 2007.

Export of live pigs increased by 1.5 times. Almost all pigs were exported to Russia. In 2008 the number of pigs exported to Russia amounted to 353,1 thousand heads for LTL 149 million (85%). Only small amount of pork was exported – some 5,3 thousand tons. Export refund payments are granted for export of pork into third countries (12%). In 2008 pig slaughterhouses received LTL 208 thousand of export refund payments.

Table 2.35. Meat exports by kind in 2004–2008, in thousand tons

Meat by kind	2004	2005	2006	2007	2008*
Meat, total	20,6	42,2	56,1	79,3	71,4
of which:					
beef	11,0	24,2	27,0	35,5	25,7
pork	2,5	3,0	6,3	12,6	5,3
poultry	6,4	13,4	17,4	21,6	15,5

* LIAE calculation.

Sources: *Agriculture in Lithuania 2007*. – V.: Department of Statistics to the GovRL, 2008;
MoA Foreign trade data base (Data of the Department of Statistics to the GovRL).

Export of Lithuanian poultry has also decreased in 2008. In comparison with 2007, export of poultry meat decreased by 9.9% and for 4.7% smaller amount. Such situation might have been influenced by the general unfavourable economic situation in the world, and a considerable price jump on the Lithuanian poultry meat within recent years.

In 2008 Lithuania imported 129,7 thousand tons of meat (Table 2.36), mostly pork.

Table 2.36. Meat imports by kind in 2004–2008, in thousand tons

Meat by kind	2004	2005	2006	2007	2008*
Meat, total	60,9	76,3	95,1	123,3	129,7
of which:					
beef	1,4	1,2	4,6	6,2	5,0
pork	30,8	35,5	45,9	70,3	73,2
poultry	21,7	31,1	34,2	36,4	31,5

* LIAE calculation

Sources: *Agriculture in Lithuania 2007*. – V.: Department of Statistics to the GovRL, 2008;
MoA Foreign trade data base (Data of the Department of Statistics to the GovRL).

Beef import in 2008 by value expression was by 27% higher, but accounted only for approximately 5% of the total meat import balance. Half of the amount of beef was imported from Latvia, and one fourth – from Poland. Import of live cattle from Latvia increased by 2 times (for LTL 6,6 million), and import from Poland amounted to LTL 14,3 million.

Import of pork in 2008 amounted to 73,2 thousand tons for LTL 466,4 million, mostly from Poland (31%), Germany (28%), and Estonia (11%).

Import of poultry in 2008 exceeded export by more than 2 times and accounted for 49% of the poultry carcass meat produced in Lithuania. Import of poultry in 2008 was by 8.5% less than in 2007 and for a smaller amount by 4%.

III. STRUCTURAL CHANGES IN THE AGRICULTURAL AND FOOD SECTOR

1. Gross agricultural output

According to the data of the Department of Statistics to the GovLR, gross agricultural output in 2008 at current prices amounted to LTL 7 214,9 million, and increased by 4% in comparison with the year of 2007. Growth of the gross agricultural output was stimulated by the increasing demand in agricultural and food products on the domestic market and the expanding volume of foreign trade. The increasing EU support conditioned further positive changes.

In 2008, gross value added of 7.4% in the country was produced by agriculture and food industry, including the share of 3.9% produced by agriculture (LTL 3 916,0 million), and of 3.5% (LTL 3 493,3 million) produced in the food industry.

In 2008 similar developmental trends remained in the branches of agricultural production as in 2007. Gross value of the crop output increased by 2% in 2008 as compared with 2007, due to the enlarged production scope. Grain crop harvest in 2008 increased by 13% in comparison with 2007 (due to the enlarged crop area by 1%, and to the increased productivity by 12%). Rapeseed harvest increased by 6% (due to the increased productivity by 14%, as the area decreased by 7%). Sugar-beet harvest decreased by 58% (because of 18% lower productivity, and by 49% reduced area). Potato harvest was higher by 24% (due to 1.4 times higher productivity, as the area was reduced by 8%); of field vegetables – by 12% (due to 17% higher productivity, as the area was reduced by 5%). Purchase prices on most of crop production in 2008 decreased in comparison with 2007: purchase price on grain and vegetables accounted for 90%, on potato – for 74%, and on fruit and berries – for 53% of the purchase price of 2007. Rapeseed and sugar-beet was purchased at much higher (by 33% and 37%) price.

Gross value in livestock production of 2008, as compared with 2007, increased by 7% due to the increased purchase prices on milk, poultry and eggs. In 2008, in comparison with 2007, live weight production was less by 26% of pork and 19% of beef and veal, by 3% leas of milk, and by 7% less of eggs. The production of poultry meat increased by 5%. Increase in purchase prices on different kinds of livestock production was not similar: purchase price on poultry and milk increased correspondingly by 3% and 4%, on eggs, pigs and cattle – by 18%, 21% and 24% respectively.

Such situation conditioned structural changes in various sectors of agricultural production. In 2007 crop production accounted for 52.7% of the gross value of agricultural production, and in 2008 – it increased by 3.8 per cent points, accounting for 56.5%.

The volume and structural changes of the agricultural production were also affected by the ever changing market conditions. The quantities of purchased agricultural production by separate types during the period of recent five years varied unevenly (Table 3.1.).

Table 3.1. Quantities of agricultural products purchased in 2004–2008, in thou. tons

Products	2004	2005	2006	2007	2008
Grain	1390,4	1768,4	1149,4	1774,4	2405,9
Flax fibre	4,6	2,0	...	0,4	0,1
Sugar beet	904,9	798,5	716,4	799,9	339,1
Rape	172,6	215,1	136,5	329,8	299,4
Vegetables	26,1	27,6	31,0	42,4	55,9
Fruit and berries	12,8	72,1	79,8	57,0	39,6
Livestock and poultry (live weight)	196,8	232,6	251,9	271,3	242,6
Milk (equivalent of base fatness)	1370,3	1432,3	1555,2	1628,2	1661,3
Eggs, mill.	485,7	487,4	483,3	486,0	454,4

Sources: Purchase of agricultural products 2004–2008. Vilnius: Department of Statistics to the GovLR.

In 2008, as compared with 2007, procurement of grain and vegetables increased by 36% and 32%, but decreased by 9%, 30% and 58% correspondingly of rapeseed, fruit and berries, and sugar-beet. Procurement of livestock production increased by 2% of milk, but decreased by 11% and 6% correspondingly of animals and poultry, and eggs.

Price index variation tendencies during the entire reference period were different. Purchase price indexes on agricultural production and inputs in 2009 were calculated according to a different methodology, therefore comparison of the presented here data with corresponding indexes referred to in previous publications is impossible. The highest price index on crop production was reached in 2007, and increased in comparison with 2005 even by 35.0 per cent points. In 2008 prices on crop production, as compared with 2007, increased by 6.2%. The highest purchase price index on livestock production was in 2008, when purchase prices, in comparison with 2007, increased by 12.7%. The highest price index on inputs was in 2008, when prices on inputs in comparison with 2007 increased by 21.6 per cent points.

Data of the analysis of the 2006–2008 period revealed that disproportion (“price scissors”) between the purchase price on agricultural production and the price on inputs varied unevenly in different years (Table 3.2.).

Table 3.2. Price indices of agricultural products and inputs in 2004–2008 (compared to the previous year), in per cent

Indicators	2004	2005	2006	2007	2008
„Price scissors“	98,8	104,3	81,8
Purchase price indices of agricultural products:					
total	106,7	104,7	106,5	117,6	110,0
crop products	100,2	95,6	117,3	130,6	106,2
livestock products	110,9	109,9	101,2	110,0	112,7
Price index of inputs	107,8	112,8	134,4

Sources: Data of the Department of Statistics to the GovLR.

The most unfavourable year for agricultural producers was the year of 2008: prices on crop and livestock production in comparison with 2007 increased correspondingly by 6.2% and 12.7%, but prices on inputs were increasing much more rapidly – by 33.2%. The year of 2007 was the most favourable year for agricultural producers, when they could acquire more inputs for the sold production, as the price growth rate of inputs was slower than of purchase prices on agricultural production. In 2006 and 2007 crop production was more profitable and the price index on crops was much higher than of inputs. Unfavourable impact of “price scissors” on agricultural production was reimbursed to Lithuanian producers by higher direct payments after the accession to the EU.

2. Structure of entities in agriculture and food industry

Agricultural entities. The number of agricultural entities by categories varied during the period of 2004–2008 unevenly. In 2008, as compared with 2004, the number of registered farmer farms increased by 41.2%, and in comparison with 2007 – by 6.9%. During the referred five years the number of agricultural partnerships and other agricultural enterprises, which declared UAA, increased by 12.3%, and the number of inhabitants, who declared individual farms, decreased by 33.7% (Table 3.3).

Table 3.3. Number of agricultural entities in Lithuania in 2004–2008

Agricultural entities	2004	2005	2006	2007	2008
Registered farmer farms, thou.	76,5	85,9	94,2	101,0	108,0
Agricultural companies and enterprises	536	543	558	586	602
Households, thou.	163,9	153,1	139,9	125,3	108,7

Source: Data of the Centre of Agricultural Information and Rural Business.

The average farm size in Lithuania by the declared in 2008 UAA and crop areas of all agricultural entities was 14,4 ha, i. e. by 7.5% larger than in 2007, however, in total by 7.7% less area units were declared. Such situation was conditioned by several factors. Streamlining processes facilitate the enlargement of farms. Some farmers refuse to declare areas because of the requirements set on good agrarian and environmental conditions. Moreover, some senior farmers receiving the EU support retire and withdraw from commercial agricultural production.

As mentioned before, the average size of a farm in Lithuania in 2008 was 14,4 ha of UAA, i. e. by 12.5% larger than the EU-27 average, and by 63.3% larger than the average of the EU-10 member states (Fig. 3.1). The largest average farms in 2008 in the EU were in the Check Republic (91,4 ha), in the United Kingdom (64,8 ha) and Denmark (60,2 ha), and the smallest – in Malta, Romania and Cyprus (1,0 ha, 3,6 ha and 3,7 ha correspondingly).

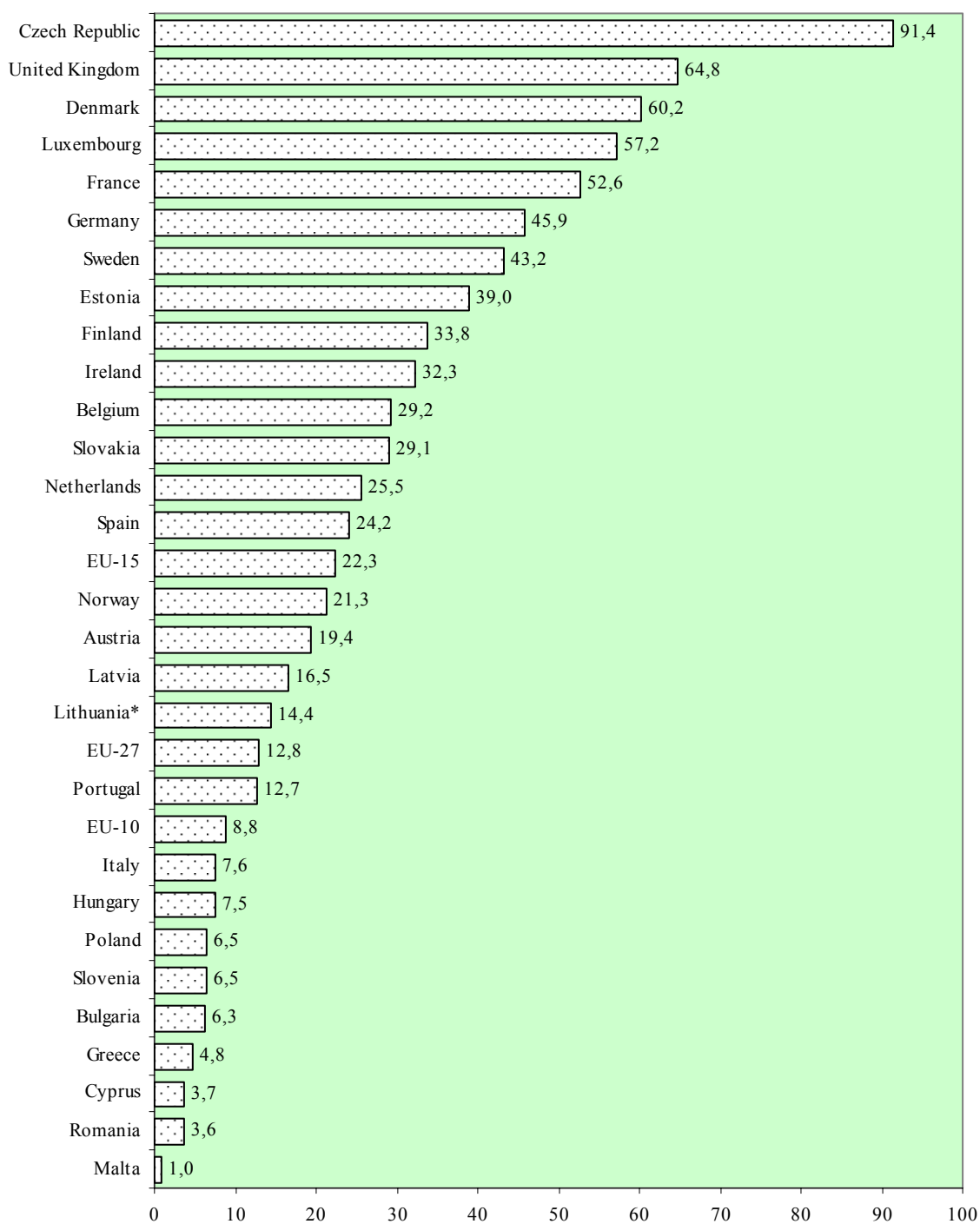

* 2008

Fig. 3.1. Average farm size in the EU countries in 2007, in hectares

Source: Eurostat data. Data of the Agricultural Information and Rural Business Centre

Analysis of the structure of farms by area and the number in Lithuania and in some other EU member states revealed that the structure of farms in Lithuania is irrational: 88% of farms are small, up to 20 ha and covering up to 33% of the total area of all farms in the country. The situation is relatively worse in Bulgaria (by number – 98%, by area – 15%), in Slovenia (by number – 96%, by area – 73%), and in Poland (by

number – 94%, by area – 57%). Most of large farms (over 100 ha) are in Denmark (by number – 19%, by area – 61%), in Luxembourg (by number – 18%, by area – 47%), in France and the United Kingdom 17% and 16% respectively. A rather interesting farm system is created in Slovakia and Czech Republic, where farms larger than 100 ha by area cover correspondingly 90% and 88% of the total UAA, and by number – 3% and 11%. However, smaller farms of less than 5 ha in the said countries account by number for 87% and 49%, respectively. In Lithuania, farms larger than 100 ha, account for 2%, managing up to 40% of the total UAA (Table 3.4).

Table 3.4. Farm structure by area and number in the EU countries in 2007, in per cent

Country	<5 ha		5,1–20 ha		20,1–50 ha		50,1–100 ha		>100 ha	
	area	number	area	number	area	number	area	number	area	number
Belgium	2	24	11	29	32	28	34	14	21	4
Bulgaria	10	95	5	3	4	1	5	0	77	1
Czech Republic	1	49	2	22	4	12	5	6	88	11
Denmark	0	3	7	39	13	24	19	16	61	19
Germany	1	22	8	32	16	22	22	14	52	9
Estonia	2	36	10	40	10	13	8	4	69	7
Ireland	1	6	14	36	39	39	29	14	16	4
Greece	26	76	37	20	22	4	9	1	5	0
Spain	5	52	11	27	14	11	14	5	56	5
France	1	24	4	19	12	19	28	20	55	17
Italy	16	73	24	19	20	5	14	2	25	1
Cyprus	29	86	27	11	16	2	11	1	17	0
Latvia	6	41	27	44	18	10	11	3	38	2
Lithuania*	10	53	23	35	15	7	11	2	40	2
Luxembourg	1	17	3	17	10	17	39	30	47	18
Hungary	7	88	9	7	9	2	9	1	65	1
Netherlands	2	26	13	31	37	28	32	12	16	3
Austria	4	33	23	40	32	20	17	5	24	2
Poland	18	68	39	26	19	4	7	1	17	0
Portugal	10	72	15	20	11	4	9	2	56	2
Romania	35	90	21	10	3	0	2	0	38	0
Slovenia	22	59	51	37	16	4	4	0	7	0
Slovakia	3	87	2	7	2	2	3	1	90	3
Finland	1	9	12	34	34	36	33	16	20	5
Sweden	1	14	10	38	17	23	23	14	49	11
United Kingdom	1	27	4	24	10	19	15	14	70	16
Norway	1	10	28	50	48	34	17	6	5	1

* 2008

Source: Data of Eurostat and of the Agricultural Information and Rural Business Centre (Information system for identifying land plots)

It was noted by investigating the structure of livestock units at different size farms, that the largest share of livestock units in the old EU member states is concentrated at large farms managing 100 ha and more (in Denmark – 66%, in Sweden – 48%). In the Czech Republic and Slovakia this share accounts even for 70%, in Estonia – for 62%). It could be explained by the fact that large farms dominate in the mentioned countries. Among the new EU member states, particularly small scale farms up to 5 ha prevail in Bulgaria and Romania, subsequently 74% and 66% of livestock units correspondingly are kept there (Table 3.5.).

Table 3.5. Structure of livestock units in farms of different size in the EU countries in 2007, in per cent

Country	<5 ha	5,1–20 ha	20,1–50 ha	50,1–100 ha	>100 ha
Belgium	14	18	36	23	9
Bulgaria	74	9	4	2	11
Czech Republic	20	3	3	3	70
Denmark	8	3	6	17	66
Germany	6	8	22	31	33
Estonia	22	5	6	5	62
Ireland	2	14	40	31	13
Greece	44	31	16	7	3
Spain	29	19	17	11	23
France	7	5	16	34	38
Italy	15	27	24	15	19
Cyprus	60	16	13	6	6
Latvia	15	28	17	11	29
Lithuania	24	25	15	9	27
Luxembourg	1	2	8	42	47
Hungary	44	9	7	4	36
Netherlands	25	23	30	17	5
Austria	6	33	47	12	2
Poland	16	42	24	6	12
Portugal	30	21	13	8	27
Romania	66	22	3	2	6
Slovenia	24	51	18	4	3
Slovakia	23	3	2	2	70
Finland	5	7	32	36	20
Sweden	7	6	14	24	48
United Kingdom	11	8	13	21	47
Norway	14	27	44	12	3

Source: Eurostat data.

According to the data of the Centre of Agricultural Information and Rural Enterprise, by the end of 2008 the Lithuanian Register of holdings recorded 359,1 thousand of natural persons – owners of the holdings, managing 4,3 million ha of the total land area, covering 60.4% or 2,6 million ha of UAA. The average size of a holding in 2008 by the total area of the holding was 12,02 ha, by UAA – 7,26 ha, and decreased in comparison with 2007 by 21.9%. Presumably, the decrease resulted from the active registration of agricultural and rural holdings, aimed at gaining the EU support. Holdings managing up to 5 ha of UAA accounted for 72.4% of the total number of holdings (covering 22.3% of the total area of UAA), larger holdings over 100 ha – for 0.7% (covering approximately 26.4% of UAA), (Fig. 3.2).

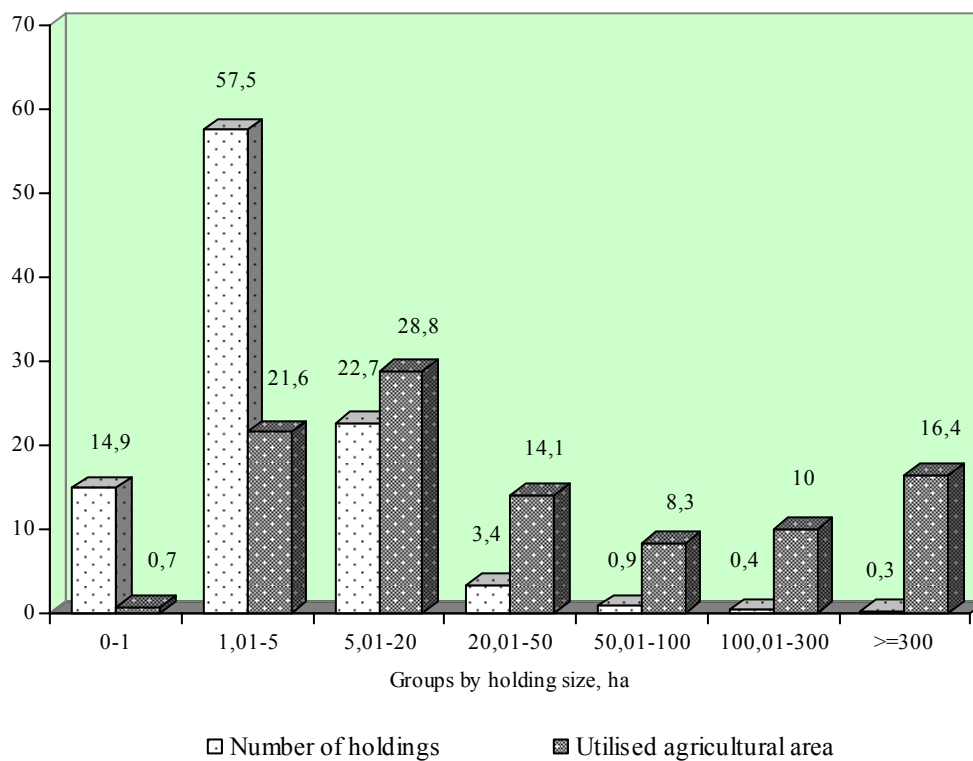

Fig. 3.2. Share of different size farm groups and share of utilised agricultural area in Lithuania in 2008, in per cent

Source: Data of the Centre of Agricultural Information and Rural Business

Some 54.3% of all holdings are registered in the favourable for farming areas, and 8.9% (or 6.4% of the total number of registered UAA) – in highly disadvantaged areas. It might be stated referring to the survey of holdings by the age of owners and distribution, that about one half of the owners of holdings are over 61, accounting for the largest share of 57% in highly disadvantaged areas. Young farmers under 40 account for the largest share of 15.5% in less disadvantaged areas (Table 3.6).

Table 3.6. Distribution of holdings by region and owner's age in 2008

Indicators	Highly disadvantaged areas	Less disadvantaged areas	Favourable farming areas
Number of holdings, %	8,9	36,8	54,3
Area of holdings, %	6,4	37,2	56,4
Average size of a holding, ha	5,2	7,3	7,5
Number of holding owners by age, %	< 40 m.	10,5	15,5
	40–60 m.	32,5	35,8
	> 61 m.	57,0	48,7

Source: Data of the Agricultural Information and Rural Business Centre

Almost one third of UAA is managed by 108 thousand of registered owners of farmer farms. This number increased within the year of 2008 by 6.9%. During the period of 2007–2008 the number of registered small scale farms up to 3 ha increased mostly – by 16%, and the number of farms managing over 50 ha increased only by 0.4% (Fig. 3.3). Such situation developed because of the possibility for the inhabitants from large cities to become farmers acquiring the entitlement for building living houses on the agricultural land.

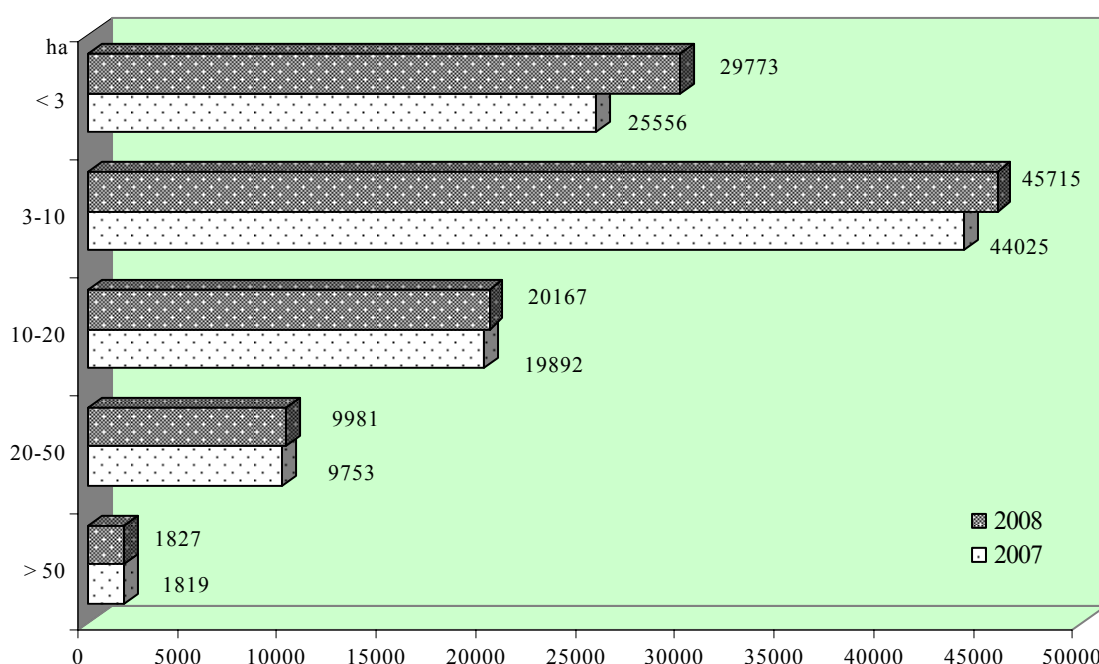

Fig. 3.3. Number of registered family farms by size in 2007 and 2008

Source: Data of the Agricultural Information and Rural Business Centre

The structure of registered farmers by age is slightly different from the structure of holding owners, as individuals in the age of retirement account only for 41% in this group, and individuals under 40, i.e. young farmers – for 18% (Fig. 3.4.).

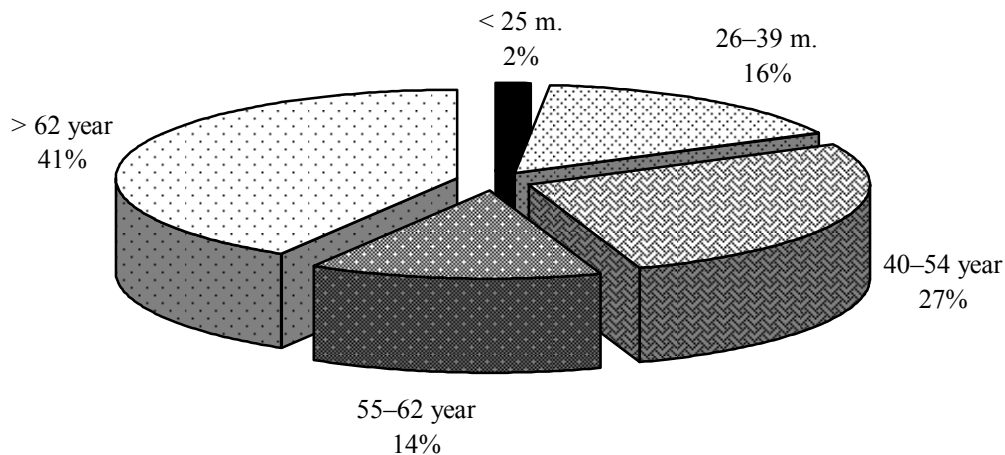

Fig. 3.4. Structure of registered family farms by age in 2008

Source: Data of the Centre of Agricultural Information and Rural Business

The EU CAP measures influence the process of farm restructuring. According to the Rural Development Plan for 2007–2013, as during the previous period, senior farmers are entitled to retirement by discontinuing commercial agricultural production and transferring land holdings to younger farmers. Aiming at facilitating the process of farm restructuring, support is granted to semi-subsistence farms by reorganising them into commercial farms. Moreover, support is also provided to agricultural entities implementing the EU veterinary, sanitary and environmental requirements.

In 2007–2008 the NPA received 216,6 thousand applications for the EU support, requesting for LTL 1,7 billion. The number of applications received during the reference period according to Axis I measures (for the improvement of competitiveness in the agricultural, food and forestry sector) amounted to 4 421, requesting for LTL 811 million. Rural people found two measures most attractive for them – “Setting up of young farmers”, and “Early retirement withdrawing from commercial agricultural production” (the number of applications received was 1 246 and 1 138 accordingly). The most distinguished measures by the requested amount were the following: “Modernisation of agricultural holdings” (the requested amount – LTL 366,8 million) and “Setting up of young farmers” (the requested amount – LTL 164,8 million). 2 888 agreements were signed under Axis I measures for the requested amount of LTL 360 million, including 32% for each measure of “Setting up of young farmers” and “Early retirement”.

The most attractive measure under Axis II (Improvement of the environment and the landscape) was “Payments to farmers in areas with handicaps, other than mountain areas (less favoured farming areas)”. In total, 200,6 thousand applications were received, requesting for the amount of LTL 435,3 million. Under this measure LTL 284,7 million was paid and 113 thousand agreements signed. Under Axis III (Improvement of life quality in rural areas and diversification of rural economy) measures 221 application was received. Most of them are related to the encouragement of rural tourism, however, no agreements were signed yet. Under Axis IV (Leader) measures 34 applications were received, 11 agreements signed, and LTL 748 thousand paid. Under Axis V (Technical assistance) measures 4 applications were received, 2 agreements signed, and LTL 75,3 million of support paid.

Food production companies. 882 food production companies were operating in Lithuania in 2008, including 34.4% of individual enterprises. During the period of 2004 – 2008 the total number of companies decreased by 25.9%, and of individual – by more than 41.1% (Fig. 3.5).

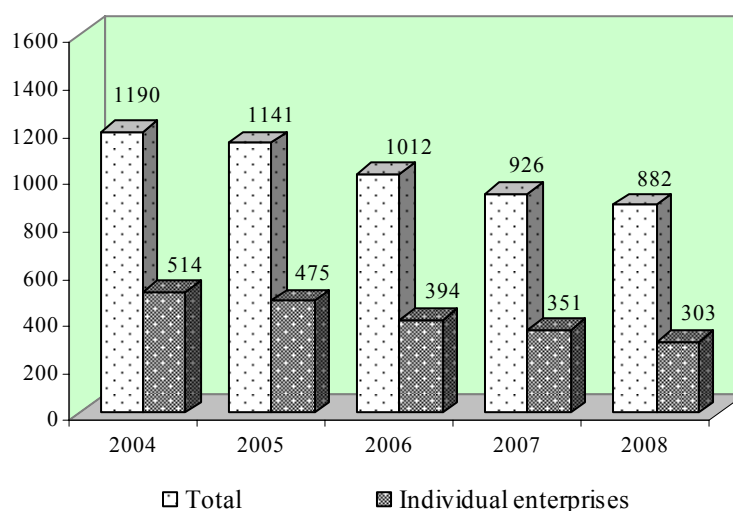

Fig. 3.5. Number of enterprises in the sector of food and beverage production in 2004–2008

Sources: Data of the Department of Statistics to the GovLR.

During the reference period the number of companies was decreasing almost in all sectors of food production, and most rapidly in the sectors of milk and dairy products, grain milling, meat and meat products, by 16%, 14% and 6% correspondingly (Table 3.7.).

Table 3.7. Food production entities in 2003–2007

Indicators	2004	2005	2006	2007	2008
Production of foodstuffs and beverages					
Number of enterprises	1190	1141	1012	926	882
Number of employees	52909	51678	52176	46613	47183
Sold output on the domestic market, mill. Lt	4691,7	4747,4	5497,5	6653	7468,4
Exports, mill. Lt	2078,4	2387,2	2800,4	3744	3909,1
Production of grain milling and starch products					
Number of enterprises	69	51	44	39	34
Number of employees	1314	1741	1289	1142	1091
Sold output on the domestic market, mill. Lt	162,8	163,8	188,1	190	180,9
Exports, mill. Lt	31,5	52,0	64,6	110	167,2

Indicators	2004	2005	2006	2007	2008
Production of meat and meat products					
Number of enterprises	264	263	226	193	182
Number of employees	9758	9876	10980	10512	10421
Sold output on the domestic market, mill. Lt	1001,6	1030,1	1204,8	1341	1571,1
Export, mill. Lt	90,7	174,4	276,6	382	420,1
Production of milk and dairy products					
Number of enterprises	32	31	30	32	27
Number of employees	10877	9806	9386	6054	6346
Sold output on the domestic market, mill. Lt	815,2	827,8	1035,2	1411	1662,9
Exports, mill. Lt	862,2	833,2	990,8	1399	1330,2
Preservation and processing of fish and fish products					
Number of enterprises	67	70	55	50	48
Number of employees	4743	4829	4742	4616	4601
Sold output on the domestic market, mill. Lt	226,7	243,0	220,9	211	234,1
Exports, mill. Lt	354,6	465,9	504,0	597	629,4
Preparation, processing and conservation of fruit, berries and vegetables					
Number of enterprises	37	35	30	34	34
Number of employees	843	752	854	979	1033
Sold output on the domestic market, mill. Lt	76,2	76,8	83,3	101	131,3
Exports, mill. Lt	23,4	35,9	29,3	43	56,8

Sources: Data of the Department of Statistics to the GovLR.

In 2008 most of companies were engaged in bread (including fresh confectionary articles and cakes) and meat, including meat products, production sectors. However, by the number of employees they were relatively smaller than enterprises of other sectors. The largest companies were operating in the sector producing milk and dairy products.

The total number of employees in the sector of food and beverage production in 2008 increased in comparison with 2007 by 1.2%, however, as compared with 2004, it decreased by 10.8%. During the reference period of 2004–2008 it has mostly decreased in 2007. Tendencies in various sectors were different. In 2008, as compared with 2007, the number of employees increased in the sectors of producing, processing and canning milk and dairy products, and fruit and berries (correspondingly by 4.8% and 5.5%), but in comparison with 2004, the number of employees decreased in the sectors producing ground grain foodstuffs, starch and its products, milk and dairy products, fish and prepared or processed fish products.

Some 41.1% of all food and beverage production enterprises operating in Lithuania should be attributed to micro-enterprises by the number of employees (less than 10 employees), 36.4% – to small, and over 17.6% – to the medium-size enterprises (Fig. 3.6.). Companies with more than 250 employees accounted in 2008 only for 4.9%, however, they employed almost 47.5% of all employees working in the sector of food and beverage production.

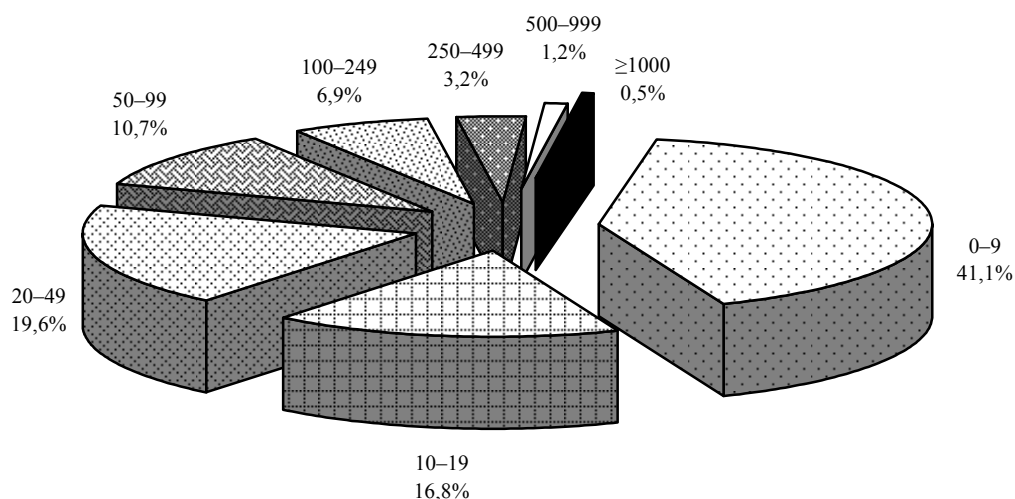

Fig. 3.6. Structure of food and beverage production enterprises by the number of employees in 2008

Sources: Data of the Department of Statistics to the GovLR.

Though the share of medium and large enterprises (by the number of employees) cover only a small part in the structure of food and beverage production enterprises in Lithuania, as in Latvia and Estonia, it is substantially bigger than in the old EU member states (Table 3.8.).

Table 3.8. Structure of food and beverage production enterprises by the number of employees in Lithuania and the selected EU countries in 2006, in per cent

Country	Number of employers					Total
	1-9	10-19	20-49	50-249	≥ 250	
EU-27	79	11	6	4	1	100
Czech Republic	72	10	9	7	1	100
Denmark	53	24	14	6	2	100
Estonia	39	21	20	15	5	100
France	89	6	3	2	0	100
Latvia	44	16	16	19	4	100
Lithuania*	45	16	19	16	4	100
Netherlands	66	16	9	7	2	100
Austria	64	19	11	5	1	100
Poland	71	9	10	7	2	100
Portugal	80	11	6	3	0	100
Romania	70	13	10	6	1	100
Slovenia	78	9	6	5	2	100
Finland	80	8	6	5	1	100
Sweden	79	9	7	4	1	100

* 2007

Source: Eurostat data

Concentration process of production in the Lithuanian sector of food and beverage industry persists. During the period of 2004–2008, when the total number of employees decreased by 10.8%, the average number of employees per enterprise increased by 20.5% (from 44 to 53). The average number of employees in separate sectors was rather different: the smallest number was in the sector of preparing, processing and canning fruit, berries and vegetables (30 on the average), and the biggest – in the sector of producing milk and dairy products (235).

In 2008, as compared with 2004, the average number of employees in the sector producing ground grain products, starch and its products increased by 68%, and in the sector of meat and meat products – by 55%, but in the sector of milk and dairy products it decreased almost by 31% as a result of automation of production processes and the implementation of new technologies.

The volume of production output indicate the changes and the level of production concentration. In 2004 the sales of one food and beverage production enterprise amounted to LTL 5,7 million on the average, and in 2008, as compared with 2004, the volume of sales per enterprise increased almost by 2.3 times.

Concentration was most rapidly increasing in the sector producing ground grain products, starch and its products, where the average production volume of the sector during the period of five years increased by 3.6 times, and in the sector of meat and meat products – by 2.6 times correspondingly.

The highest production concentration developed in the sector producing milk and dairy products, where the average volume of production output per enterprise in 2008 amounted to LTL 110,9 million, and the five largest companies produced approximately 90% of the total output of the sector. Almost by 40% higher than the average volume of food production output per enterprise was achieved in the sector of preparing and processing fish and fish products.

The level of production concentration in food industry was rapidly increasing. According to the Eurostat data, the average revenues per enterprise in the Lithuanian sector of food industry exceeded average revenues per enterprise in the EU-27 member states, and is not far behind from the average revenues per enterprise in some old EU member states (Spain, Greece) (Fig. 3.7).

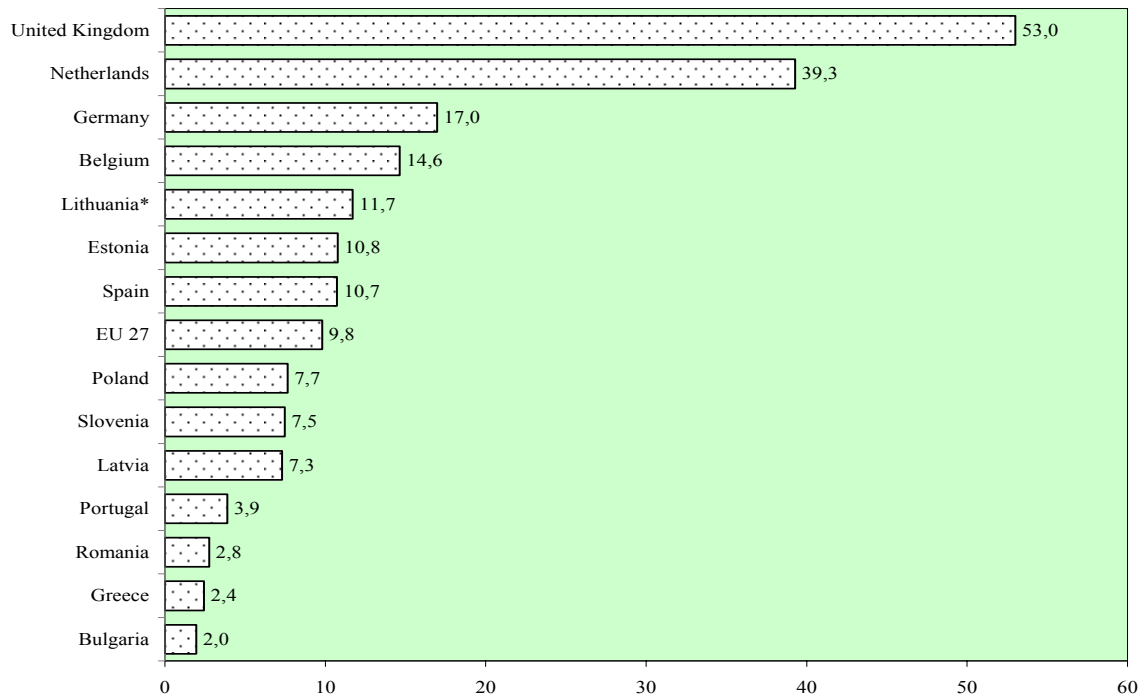

* 2008

Fig. 3.7. Average revenues from food and beverage production per enterprise in Lithuania and the selected EU countries in 2006, in million Litass

Sources: Eurostat data. Data of the Department of Statistics to the GovLR.

According to the data of the Department of Statistics, most of food production companies are located close to the largest cities of Lithuania: 23.6% of all food and beverage production enterprises are located in the county of Kaunas, and over 17.2% in the county of Vilnius. Only few food production companies are operating in the counties of Utena and Alytus, accounting for some 3.5% and 3.6% respectively (Fig. 3.8).

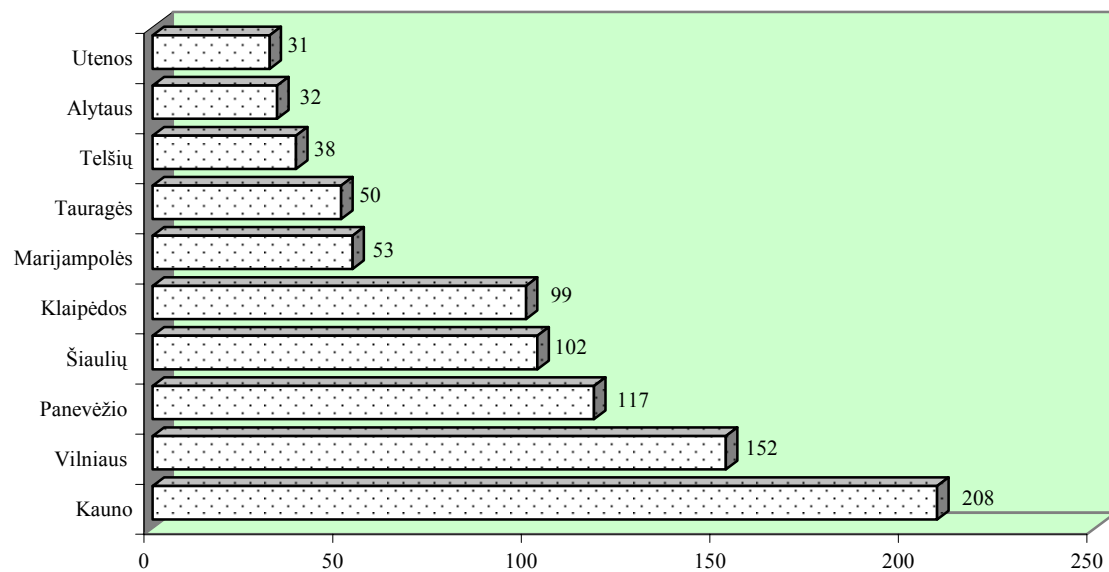

Fig. 3.8. Number of food and beverage production enterprises in Lithuania by counties, at the end of 2008

Source: Data of the Department of Statistics to the GovLR.

According to the total revenues from sales, the most profitable companies are operating in the counties of Kaunas, Panevėžys, Vilnius and Klaipėda. In comparison with 2007 revenues of companies from the sales of output increased in almost all counties, most of all (by 58%) in the food and beverage production companies of Utena county. Such growth resulted from the increased production of meat and meat products. Revenues were also rapidly increasing in the companies operating in the counties of Kaunas and Alytus, by 29% and 24% accordingly. Revenues of companies have slightly decreased by 6% only in the county of Tauragė.

The highest concentration of production by revenues from the sales of foodstuffs and beverages was in the counties of Utena, Telšiai, Marijampolė and Klaipėda. One food production company in Utena county gained by 3,1 times more revenues than one company on the average in the country, and by 10 times more than one company in the county of Šiauliai. Relatively high revenues were gained by the companies in the analysed branch operating in the counties of Telšiai, Marijampolė and Klaipėda, exceeding the national average 2,3 times, by 7,7% and 7,7%, respectively.

A relatively high level of revenues on the average was conditioned by the fact that the largest food production companies, such as AB „Rokiškio sūris“, AB „Pieno žvaigždės“, and AB „Žemaitijos pienas“ were operating in the above counties.

SUMMARY

Membership of Lithuania in the EU facilitated to increase funding for agriculture by introducing new instruments of direct support and investments, reorganising alongside the state support measures. The proportion of means allocated for agriculture in the state budget of Lithuania increased by 2.16 times in 2004–2008 amounting to LTL 2 930,7 million. The EU input amounted to LTL 1 587,6 million, or 54.2%.

In 2007 the 2007–2013 National Rural Development Programme of Lithuania was approved and the new programming period started. The content of state support measures and the principles for awarding direct payments were changed. In 2008 the rules on awarding the support were amended according to the measures of 2007–2013 National Rural Development Programme, including the procedure for export refund payments; discussions of guidelines for further development of the EU common agricultural policy started, and new legal acts were adopted respectively. Such changes in the agricultural policy will subsequently influence the conditions of granting further support to the producers of agricultural and food products, the amount of the support, administration and coherence.

In 2008 the value of exported agricultural and food products amounted to LTL 8 876 million (by 20.8% more than in 2007), and the value of imported products reached LTL 8 105 million (by 32.9% more). The trade balance was positive since 2005, however, in 2008, as compared with 2007, it decreased. The foreign trade turnover increased by more than 24%. The export of agricultural and food products in 2008 accounted for 16.0% of the total export of goods, and the import – for 11.2% of the total amount of import. During the period of economic crisis, when daily commodities are more in demand, it may be presumable that trade in agricultural and food products will cover a larger part in Lithuania's foreign trade.

In 2008 the gross agricultural output amounted to LTL 7 214,9 million, and in comparison to 2007, increased by 4%. The gross value added created in agriculture and the food industry made up 7.4% of the total national gross value added (3.9% in agriculture, and 3.5% in the food industry). Similar tendencies continued in the development of agricultural sectors. In 2008, as compared to 2007, the gross value of crop production increased by 2%, and of livestock – by 7%. Such factors influenced structural changes of the common agricultural production. In 2008 it increased by 3.8% percentage points and accounted for 56.5% of the gross value of agricultural production.

The scope and structural changes in agricultural production were influenced also by the continuously alternating market conjuncture. In 2008 the purchase of grain and vegetables accounted for correspondingly 36% and 32%, more as compared with the previous year, while rapeseed, fruit and berries, and sugar beet – less by 9%, 30% and 58% respectively. The amount of milk purchased increased by 2%, but the purchased amounts of livestock and poultry, and eggs decreased by 11% and 6%, respectively.

In 2008 the number of registered farmer farms amounted to 108 thousand, and the number of agricultural companies and other agricultural enterprises was 602. With reference to the data of crop declarations of all agricultural entities, in 2008 the average farm size was 14,4 ha of UAA, or by 7.5 % larger than in 2007.. A comparatively large proportion of small semi-subsistence farms run by elderly farmers remained.

The share of employees in agriculture during the period of 2004–2008 decreased from 15.7% to 7.9% in Lithuania. Agricultural business is no longer the dominating economic activity even in rural areas of the country. In 2008 only some 24.2% of employed rural population were involved in agricultural activities influencing the importance of diversification of rural economic activities. In 2008 over 9.5 thousand of SMEs were operating in rural areas, including 74% of micro-enterprises, where 109.7 thousand of workers were employed in 2008, or 26% of all employed rural population. It accounts for 30% more than in 2004. One micro-enterprise had on the average 3 employees, small – 21, and medium – 95 employees. Rural tourism has become one of the most rapidly developing alternatives to agricultural activities in rural areas. The number of tourism services providers at the beginning of 2009 amounted to 730, or 1.2 times more than in 2007.

Future changes in the EU rural development policy encouraged to analyse problems of upholding national and ethnographic heritage products, and creating of specific legal and financial preconditions for the development of crafts as business activity. In 2008 the Law on National Heritage Products was enforced. The Description of the classification of traditional crafts covers 65 crafts and products traditionally and historically developed in Lithuania.

In 2008 experts received 46 applications for the assessment of 77 traditional articles (experts recognised 58 articles as products of national heritage, including 39 food products, 7 articles in carving, and 6 – in pottery, cross-making).